

# LEVEL.Com 101 LIQUID LEVEL COMPUTER

LEVEL.Com 101 LIQUID LEVEL  
COMPUTER

## INSTRUCTION MANUAL

Version 1.14

**TMS, Inc.**

6040 N Cutter Circle, Suite 302

Portland, Oregon 97217

Phone: 503-285-8947

Fax: 503-285-1379

Web page: <http://www.tms-usa.com>

email: [info@tms-usa.com](mailto:info@tms-usa.com)

**Copyright © 2008 Technical Marine Service, Inc.**

© Technical Marine Service, Inc 2008 v1.14

# LevelCom 101 – Specifications

<b>Design Standard</b>	The LevelCom 100 has been designed to meet the requirements of 46 CFR 62.25-30 and the American Bureau of Shipping (ABS) 1994 Rules for Building and Classing Steel Vessels, Part 4-Machinery Equipment and Systems.
<b>Approvals</b>	US: UL 3121-1 Process Control Equipment, File E214292. Canada: CUL C22.2 No. 142-1987. ABS Type Approval, Certificate PO16589-X
<b>Power</b>	115VAC / 100mA / 60Hz - Fuse: 0.25A
<b>Temperature</b>	Operating range: -10° F to +140° F (-23.33° C to +60° C)
<b>Humidity</b>	5 - 95% RH, non-condensing
<b>Enclosure</b>	NEMA 4X front (when used with gasket), membrane front face and keypad, brushed aluminum face with powder coated bezel.
<b>Dimensions</b>	14.5" (37cm) H x 5.5" (14cm) W x 3.8" (9.6cm) D
<b>Alarm Setpoints</b>	Four (4) programmable setpoints
<b>Control Setpoints</b>	Four (4) programmable setpoints
<b>Security</b>	User defined 1 - 9 character password protection
<b>Options</b>	Unit is configurable as a repeating station that provides remote display and control for a LevelCom 100.

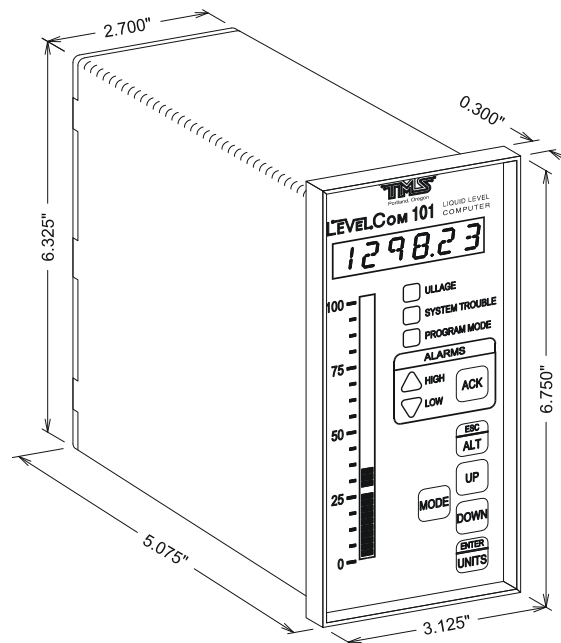

**Case Dimensions**

# Table of Contents

<b>LevelCom 101 – Specifications</b> .....	2
<b>General Information</b> .....	5
<b>Features and Definitions</b> .....	7
<b>Display Functions</b> .....	10
Digital Display Messages .....	12
Lights .....	13
Buttons .....	13
<b>Installation</b> .....	14
Choosing a Site .....	14
<b>Electrical Connections</b> .....	15
General .....	15
120 /240 VAC .....	16
Analog Input .....	16
Digital Repeater Communication .....	16
Relay Output .....	16
RS422/RS485 Serial Communications .....	17
Contact Inputs .....	17
<b>Basic Programming</b> .....	18
Basic Programming Key Functions .....	19
Entering the Program Mode .....	19
Erase All Memory - Reset Factory Defaults .....	19
Programming the Sensor Range .....	20
Programming Specific Gravity .....	20
Programming Display Setup .....	20
Output Programming - General Description .....	22
Programming Lights .....	23
Programming Relay Outputs for Alarm .....	23
Programming Horn Output .....	24
Programming Alarm Setpoints .....	24
Alarm Timeout .....	25
Serial Port Setup and Diagnostics .....	25
<b>Advanced Programming</b> .....	28
Entering the Program Mode With a Hot Menu Established .....	28
Tank Table .....	29
Password .....	30
Hot Menu .....	31
Control Relays .....	32
<b>Programming Worksheet Explained</b> .....	34
<b>Programming Worksheet</b> .....	39
<b>Troubleshooting</b> .....	41
<b>Appendix A Serial Network Wiring Diagrams</b> .....	44
<b>Appendix B MODBUS Register Values</b> .....	45
<b>Configuration Interface Map</b> .....	48

# Table of Figures

Figure 1	General Display Layout .....	5
Figure 2	Displays.....	10
Figure 3	Full Tank Display .....	11
Figure 4	Overfill Display .....	11
Figure 5	Overfill and Low Level Arrows.....	12
Figure 6	Mounting .....	14
Figure 7	Dimensions.....	14
Figure 8	General Wiring.....	15
Figure 9	Externally Powered Sensor .....	16
Figure 10	Digital Repeater Wiring .....	16
Figure 11	Buttons.....	19
Figure 12	Tank Table Example.....	29
Figure 13	5 wire RS-485 wiring .....	44
Figure 14	3 wire RS-485 wiring .....	44
Figure 15	Configuration Interface Map .....	48
Figure 16	Configuration Interface Map .....	49

# General Information

Thank you for choosing the LevelCom 101 Liquid Level Computer. You have purchased a refined, high quality and dependable instrument.

Figure 1 is a picture of the face of a LevelCom 101, showing the 6 character digital display, the 40 segment bar-graph, the alarm and status lights, and the buttons for accessing the configuration interface.

The LevelCom 101 measures the 4-20 mA analog signal from a pressure transmitter in the tank. Using the programmed value for the sensor range, and the specific gravity of the liquid in the tank this pressure reading is converted to a depth reading. This raw depth reading is then converted for display in engineering units of measure which include:

- Depth expressed in inches, feet, feet/inches, centimeters or meters
- Volume expressed in gallons, liters, cubic feet or barrels
- Weight expressed in short, long or metric tons

Volume and weight are calculated through a user configured tank curve.

The LevelCom 101 calculates the values and displays them on the front panel as 0 to 100% of tank depth on the bar graph indicator and in the desired units of measure (as depth, volume or weight) on the digital display.

The LevelCom 101 can be configured to display multiple units, for instance depth and volume. The user can configure the default display units, volume, for instance. This will be the normal units displayed. The unit can be switched to depth display by pressing the ESC/ALT button. The unit will briefly display the

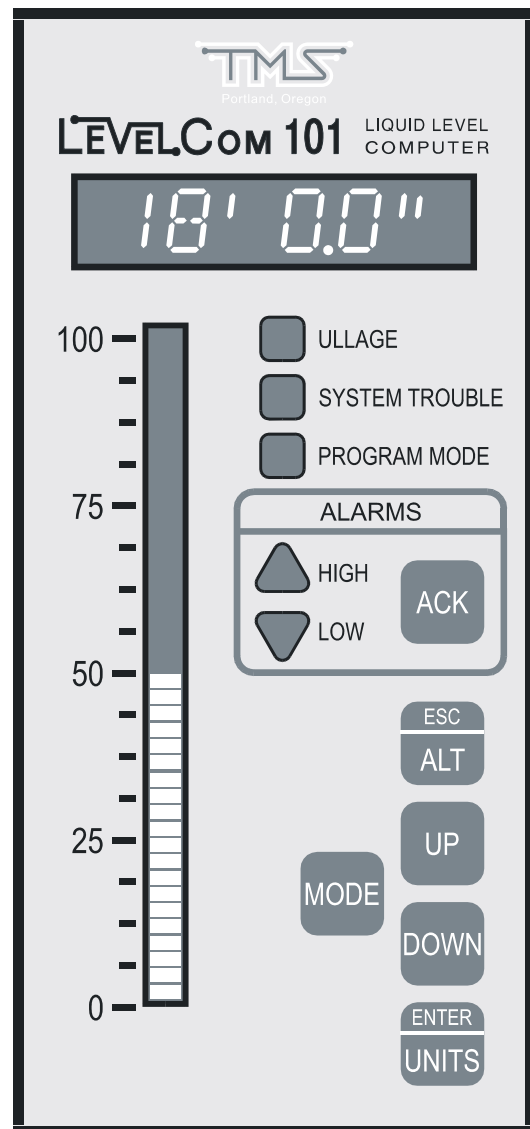

Figure 1 General Display Layout

name of the new display unit, and then display depth on the display. In normal operation the ENTER/UNITS button may be pressed to display the current display units. The ACK button is used to acknowledge alarm and fault conditions locally.

Each LevelCom 101 is field configured with the parameters and feature selections associated with the tank to be monitored. These include:

- Depth in English or metric units
- Volume in gallons, liters, barrels or cubic feet
- Weight in short, long or metric tons
- 10 point Tank Table defining the relation of depth to volume/weight
- Manual input of specific gravity
- Four alarm points with hysteresis
- A user defined password
- A **Hot Menu** to access certain user-selectable features without a password

Alternately the LevelCom 101 can be used as a repeater for a LevelCom 100. In this configuration the LevelCom 101 communicates with a LevelCom 100 through a digital serial communication interface. The LevelCom 101 receives depth, volume, and specific gravity information from the LevelCom 100. This data is then displayed in locally programmed engineering units and appears on the digital display and bargraph.

The LevelCom 101 includes three relays, two relays have form C contacts and can be configured for either alarm or control functions. The third relay has a single form A contact and is intended to drive a warning horn for local alarm indication.

The LevelCom 101 is self-diagnostic and can detect some hardware errors, like a failure of the sensor signal, or loss of the digital communication signal in the case of a digital repeater. If an abnormal condition is detected, the LevelCom 101 will display the appropriate error message on the digital display and activate an alarm to alert the operator.

# Features and Definitions

The following are definitions and explanations of LevelCom 101 features and the terminology used in this manual and the LevelCom 101 configuration interface. Messages displayed on the LevelCom 101 digital display are listed under the Display Functions section on page 12.

## Alarm Setpoint

This is a user defined reference point that establishes the point at which a particular alarm will activate. The LevelCom 101 supports four alarm setpoints, High High, High, Low, and Low Low alarm.

## Buttons

The LevelCom 100 has a set of buttons built into the face plate. These are used to enter the configuration information into the device, and to locally acknowledge alarm conditions.

## Communication

The LevelCom 101 has a built in communication interface that allows a group of LevelCom 101s to be networked to a central control or data acquisition computer. This interface is a standard RS-422/RS-485 interface using standard Modbus RTL Protocol.

## Configuration

The LevelCom 101 program allows users to configure the unit to a wide variety of situations. The unit is shipped with a default configuration and the user adjusts the functions and parameters to

match his own requirements thereby establishing the Configuration.

## Horn

The LevelCom 101 has a built in relay interface intended for driving an enunciator horn or light to signal alarms. This provides a local alarm function, the ACK button is used to acknowledge alarms and silence the horn.

## Hot Menu

The hot menu is for use when the configuration will be password protected. It is a configurable menu that allows certain parameters, like specific gravity, to be available to operators who don't have the password. This allows operators to change these parameters as needed while protecting the rest of the configuration from tampering.

## Hysteresis

A user-defined measurement between an Alarm Setpoint and the point the alarm condition will automatically clear. For example, assume a tank has a Maximum Depth of 10' 0". The Hi Alarm Setpoint is 8' 0". Hi Hysteresis has been set at 0' 6". The level in the tank must rise to 8' in order for the Hi Alarm to activate. The level must then drop to 7' 6" for the alarm to clear.

## Latch

This is a function available in the Light and Horn output sections of the program. Latch holds alarm outputs active,

even if the alarm condition has cleared, until the user presses the ACK key

## **Lights**

On the LevelCom 101 front panel there are individual LED lights to indicate alarm and fault conditions.

The High Alarm and Low Alarm lights are used to indicate existing alarm conditions. There are four possible alarm setpoints available; High High, High, Low, and Low Low alarm. High and High High alarm conditions are indicated by the High alarm light. Low and Low Low alarm conditions are indicated by the Low Alarm light. When an alarm condition occurs, the respective alarm light will flash to indicate the alarm. If the ACK button is pressed to acknowledge the alarm, the light will quit flashing and remain lit until the alarm condition clears.

The SYSTEM TROUBLE light indicates fault conditions, such as a failed sensor. When the condition occurs, the SYSTEM TROUBLE light will flash to indicate the condition. If the ACK button is pressed to acknowledge the fault, the light will quit flashing and remain lit until the fault condition clears, or another fault condition occurs.

The ULLAGE light is lit to indicate that the current value shown on the digital display is an ullage value, indicating how much of the tank remains to be filled. Typically an ullage reading will indicate 0 for a full tank, and the maximum value for an empty tank.

## **Local**

The optional alarm relays can be configured for Local Acknowledge. In this case if the relays are configured as alarm outputs the alarm output will clear when the ACK button is pressed. Otherwise the relay will clear only when the alarm condition clears.

## **Menu**

The LevelCom 101 configuration is organized as a series of menus. These menus are organized to simplify the configuration process by grouping related parameters together. The buttons on the machine front panel are used to navigate through the menus.

## **Mode**

MODE is the front panel key used to enter the LevelCom configuration menus. The MODE key is also used to make selections and activate or deactivate functions in the program.

## **Parameter**

A parameter is a number used by the LevelCom 101 to calculate a display value or to trigger an alarm. Parameters are set by the user to define the configuration of the LevelCom. Maximum Depth and Bottom Offset are parameters.

## **Password**

The LevelCom 101 can be configured for password protection of the user's configuration. The password characters are the letters A-Z. As few as 1, and as many as 9 characters can be used in the password. The LevelCom 101 may

be programmed with a Hot Menu, which allows easy access to frequently used functions and parameters. The Hot Menu is not password protected.

### **Programming**

This refers to the setup and entry of the user's configuration into the LevelCom 101.

### **Relays**

The LevelCom 101 is available with 2 optional "Form C" relays and one "Form A" horn relay. These relays can be used for alarm or control purposes. For control function the relays are intended for pilot duty only. They will not carry the current required to run a motor or large solenoid valve.

### **Specific gravity**

Specific gravity is a user-defined parameter in the program. This parameter is used to convert the static pressure reading from the sensor to a depth reading.

### **SURE?**

"SURE?" appears when the user has entered a section of the program that will erase or overwrite the configuration. The LevelCom 101 queries the user to allow time for the user to consider if he is certain of his actions. If "SURE?" appears on the display at any point in programming and you do not know why **don't press ENTER!**

# Display Functions

The LevelCom 101 displays depth, volume and weight data on two display formats, a 40-segment vertical bargraph on the left side of the front panel and a 6 character digital display on the top of the front panel. See Figure 2. There are also individual lights to indicate alarm and fault conditions.

**Bargraph:** The bargraph indicates depth only; the units are percentage

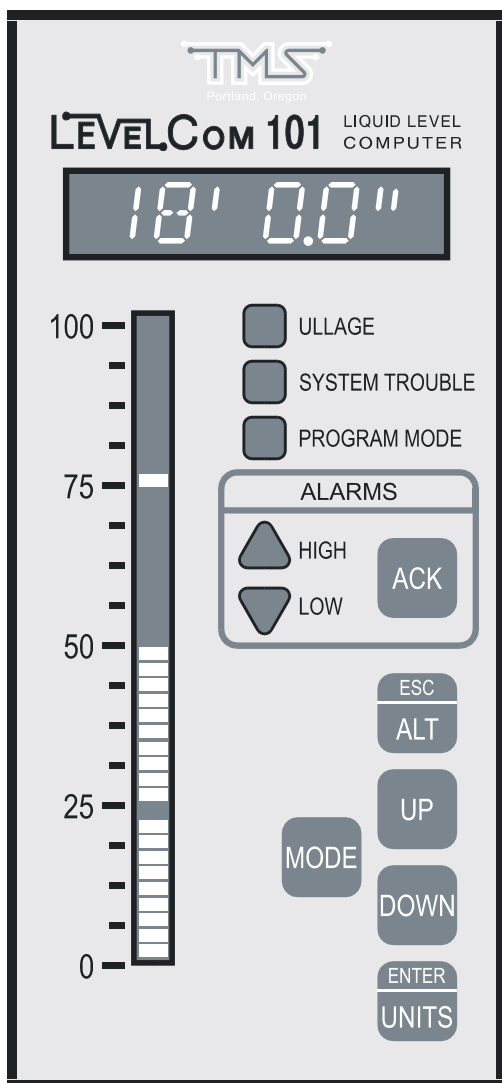

Figure 2 Displays

from 0 to 100% of the maximum depth of the tank. Alarm setpoints are shown on the bargraph as a lit segment in the dark part of the bargraph, or as a dark segment in the lit part of the bargraph. Figure 2 shows an example of this with setpoints at 25% and 75%.

Provision for indicating an overflow situation has been included. As an example, if the level of the tank exceeds 100%, the bar graph will continue to indicate the actual depth by flashing the top three segments of the bar graph indicating a level in excess of 100%. The bar graph will display the percentage of overflow by turning off the bar graph from the bottom to indicate the percentage of overflow. The percentage of overflow will be indicated up to the maximum sensor input value, or the maximum of the bargraph, whichever is lower.

**Digital:** The digital display indicates depth, volume or weight in the units of measure selected during programming. Programming information and error messages are also indicated on the digital display.

## Important Note

The following section describes the function of the LevelCom 101 in an overflow situation. TMS encourages the user to become familiar with the displays and to use extreme caution when overflowing a tank.

In a standard installation, the LevelCom 101 is normally configured to display the tank level on the bargraph indicator as 100% at the maximum depth of the tank

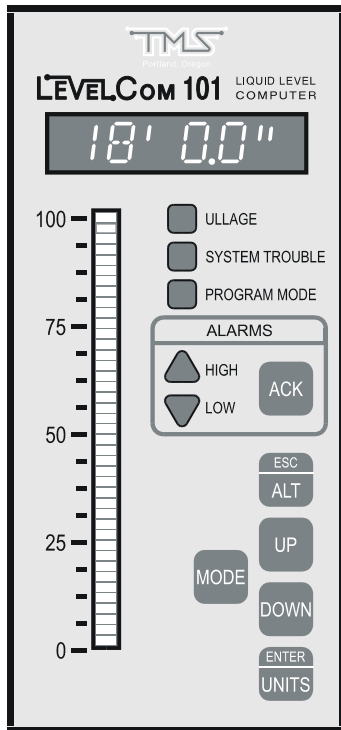

Figure 3 Full Tank Display

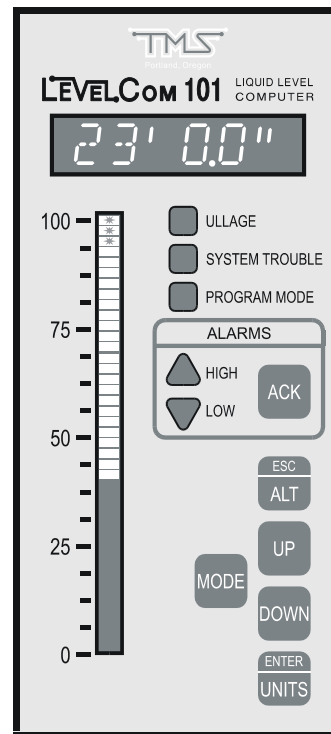

Figure 4 Overfill Display

**not** including standpipes or vents. If the tank is overfilled and liquid enters the piping system above the tank top, the LevelCom 101 will continue to update and display level indications by flashing the top 3 bargraph segments and turning off the bargraph starting at the bottom and moving upward indicating the percent of overfill.

In an overfill event depth will be displayed accurately on the digital display up to the maximum output of the sensor, and up to 150% of tank depth on the digital display. The LevelCom 101 will flash the top three bargraph segments to indicate an overfill.

Volume and weight are limited to the maximums established in the Tank Table. When the level is beyond the maximum depth of the tank, the maximum volume will be displayed with a flashing up arrow superimposed over the left most character in the display.

**Example:** assume the LevelCom 101 has been programmed to a tank with a Maximum Depth of 18 feet and a Maximum Volume of 730 bbl. Depth is being indicated on the digital display. Vent and sounding pipes run from the top of the tank to the main deck 12 feet above the top of the tank. The tank is set up to allow cascade filling of adjacent tanks through an overflow line located 5 feet above the top of the tank. Figure 3 shows the digital and bargraph displays at 100% of capacity.

While filling the tank the operator chooses to “press” the tank to ensure a complete fill. During the fill the LevelCom 101 will track the depth and volume accurately to the maximum depth of eighteen feet. At eighteen feet the bargraph will indicate 100% and the digital display will indicate 18' 0.0". As filling continues past this point, the upper three segments of the bargraph will

flash indicating a level in excess of 100%. The bargraph will darken at the bottom indicating the percentage of overfill. The digital display will indicate the actual liquid level the unit is sensing. If liquid were pressed five feet up the pipe system the LevelCom 100 will indicate "23' 0.0" on the digital display and 128% on the bargraph. Refer to Figure 4.

If the LevelCom 101 was programmed to display volume or weight then as the depth increases above Maximum Depth the LevelCom 101 will display the Maximum Volume/Weight with a flashing up arrow symbol in the left most character of the display indicating the tank volume/weight exceeds the maximum capacity. The digital display **will not** interpolate above the programmed Maximum Volume/Weight. The bargraph **will** continue to display accurate percentages of depth up to 150% overfill.

### Digital Display Messages

The LevelCom 101 has been designed to self diagnose problems and present messages on the digital display. Following is a list of messages which could be displayed by the LevelCom 101. If an error message occurs refer to the troubleshooting guide.

#### SURE?

SURE? appears when the user has entered a section of the program that will erase or overwrite the configuration. The LevelCom 100 queries the user to allow time for the user to consider if he is certain of his actions. If SURE? appears on the display at any point in pro-

gramming and you do not know why - **Don't press ENTER!**

#### EEPROM FAILURE

A failure is detected in the configuration EEPROM memory. See troubleshooting section.

#### CURRENT LOOP FAILURE

There is no input signal from the sensor. See troubleshooting section.

#### DIGITAL COMM FAILURE

In a digital repeater installation, there is no communication on the communication interface. See troubleshooting section.

#### NOT RECEIVING DATA

In a digital repeater installation the device detects traffic on the communication interface but no messages are sent to the device. See troubleshooting section.



Volume Overfill Example



Depth Low Level Example

Figure 5 Overfill and Low Level Arrows

#### Up Arrow or Down Arrow

To indicate an out of range reading the digital display will show flashing arrow symbols in the left most character of the

digital display. When the liquid level falls below the end of the sense line the machine will display the Bubbler to Bottom value with a flashing down arrow to indicate that the fluid level can no longer be measured. If the fluid level rises above the Maximum Depth level the left most character will have a flashing up arrow to indicate that the fluid level is over the top of the tank.

## Lights

On the machine front panel there are individual LED lights to indicate alarm and fault conditions.

The High Alarm and Low Alarm lights are used to indicate existing alarm conditions. There are four possible alarm setpoints available on the machine, High High, High, Low, and Low Low alarm. High and High High alarm conditions are indicated by the High alarm light. Low and Low Low alarm conditions are indicated by the Low Alarm light. When an alarm condition occurs, the respective alarm light will flash to indicate the alarm. If the ACK button is pressed to acknowledge the alarm, the light will quit flashing and remain lit until the alarm condition clears.

The SYSTEM TROUBLE light indicates fault conditions, such as a plugged sense line, low supply air pressure, or leaking sense line. When the condition occurs, the SYSTEM TROUBLE light will flash to indicate the condition. If the **ACK** button is pressed to acknowledge the fault, the light will quit flashing and remain lit until the fault condition clears, or another fault condition occurs.

The ULLAGE light is lit to indicate that the current value shown on the digital display is an ullage value, indicating how much of the tank remains to be filled. Typically an ullage reading will indicate 0 for a full tank, and the maximum value for an empty tank.

## Buttons

The front panel buttons are used in normal operation to view the display units, to switch temporarily to different display units, to locally acknowledge alarms, and to manually trigger a new reading.

To view the present display units, press the **ENTER/UNITS** button. While the button is pressed the current display units will be shown in text on the digital display, "FEET" for instance.

The LevelCom 101 may be configured with more than one display unit. For instance it might be desired to display depth as FEET, but it is also desired to display the Volume, in BARRELS. In normal operation the LevelCom 101 will display depth information. Press the **ALT/ESC** button to display the volume information. The new unit name will be shown briefly on the digital display, BARRELS in this example, and the display will then display the volume information. The display will switch back to the default units automatically after about 30 seconds, or it may be switched back by pressing the **ALT/ESC** button again.

# Installation

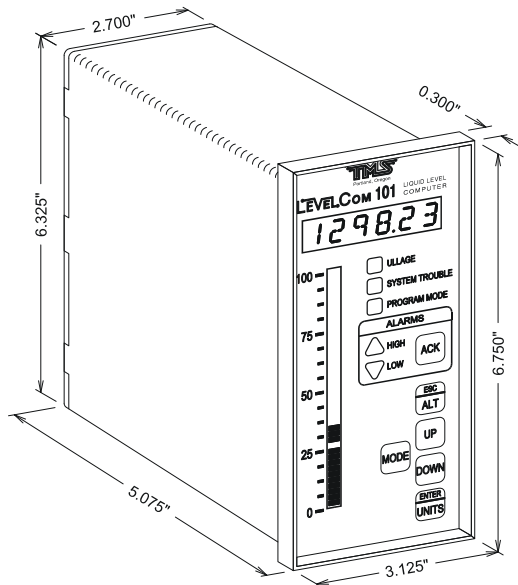

Figure 7 Dimensions

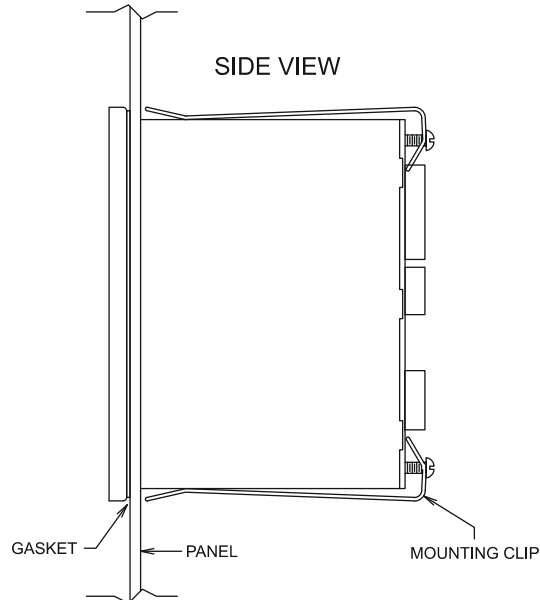

Figure 6 Mounting

## Choosing a Site

The LevelCom 101 has been designed to be mechanically rugged and well protected against adverse environments, but it is best to try to avoid areas of high moisture and temperature, excessive vibration and electrical interference. Area lighting is not required for viewing the LevelCom 101 since it has a brightly lit LED display. Electrical power, typically 120VAC, must be available.

Flush mount the unit by inserting it through the front of the panel and secure from the back with the enclosed mounting clips and screws. The cutout size is 2.750" (70mm) X 6.375" (162mm). Depth behind the bezel is 5.25" (133 mm). The enclosure depth must include enough space beyond the 5.25" depth to accommodate wiring (approx. 2"). Refer to Figure 7 and Figure 6.

# Electrical Connections

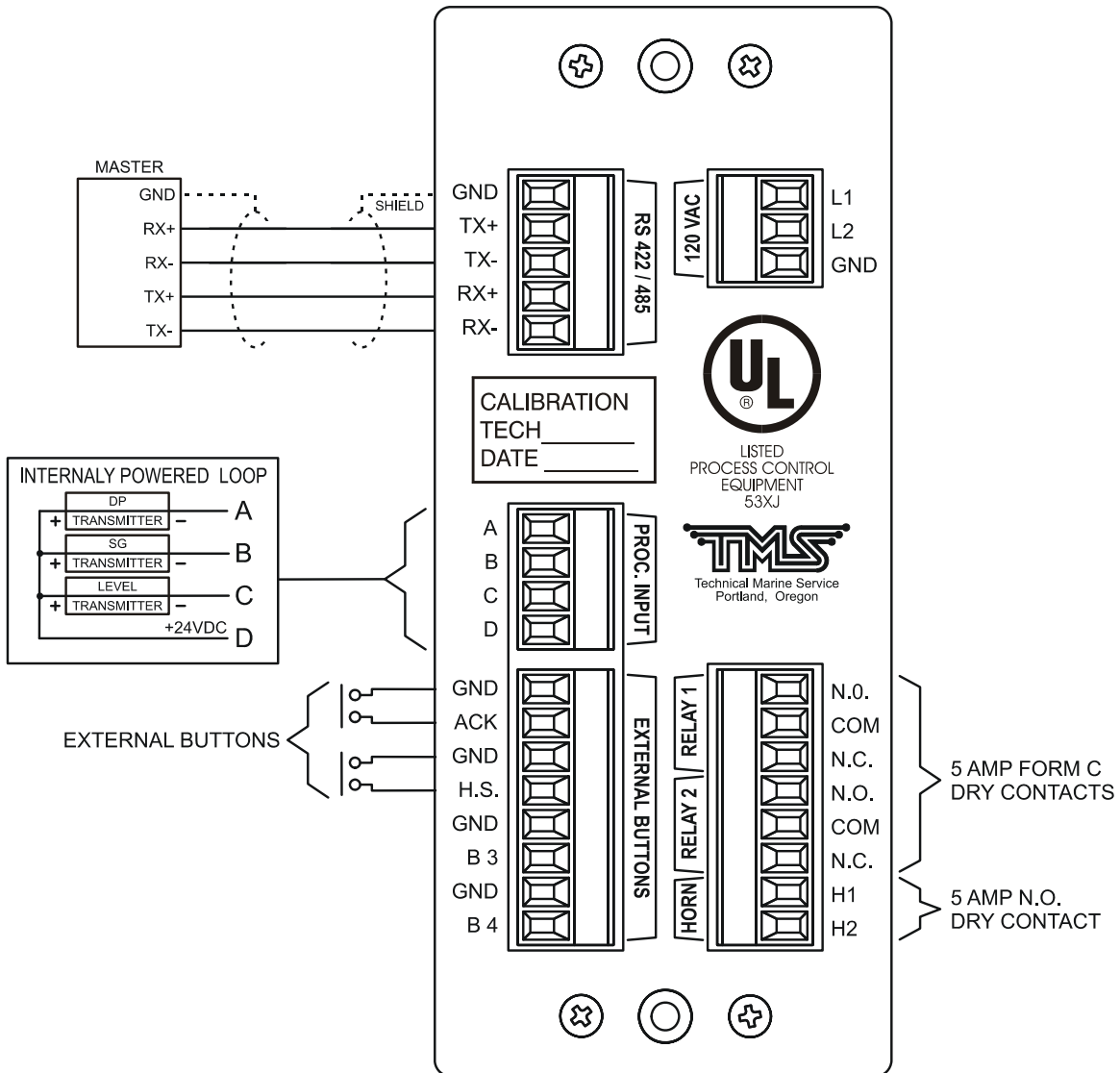

Figure 8 General Wiring

## General

When wiring the LevelCom 101 refer to the wiring diagrams in Figure 8. This drawing shows the most common wiring for the machine. Normally a single

depth sensor is connected to the machine, and normally the LevelCom 101 provides power for this sensor. There is no power switch in the LevelCom 101 so if one is required it must be provided separately. The plug and socket terminals will accept wire sizes 22 to 12

AWG. To remove any of the plugs, grasp firmly and pull straight out.

## 120 /240 VAC

Electrical power connections are made via the three-point connector located at top right on the back. The terminals are labeled [L1] [L2] [GND]. Connect wires as shown in Figure 8 General Wiring.

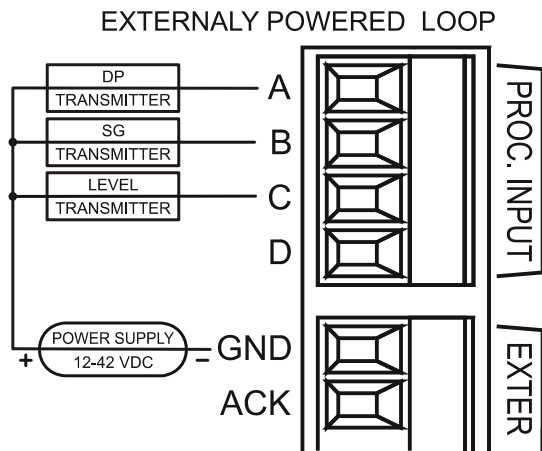

Figure 9 Externally Powered Sensor

## Analog Input

There are three (3) analog 4 to 20 mADC inputs to the LevelCom 101. The terminals are labeled A, B, C, D, and GND. The LevelCom 101 can provide 24VDC to power the current loops, or the loops can be externally powered by 12 to 42 VDC. Refer to Figure 8 for the internally powered sensor wiring.

To power the sensors with a power supply external to the LevelCom 101 refer to Figure 9. In this case the power supply ground is hooked to one of the ground connections on the External Buttons connector.

## DIGITAL REPEATER CONNECTIONS

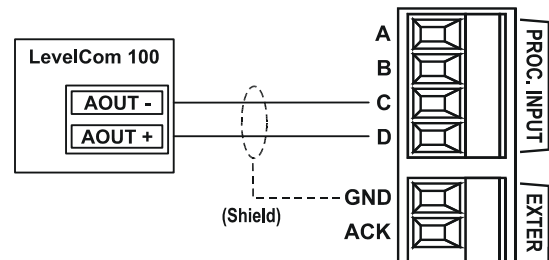

Figure 10 Digital Repeater Wiring

## Digital Repeater Communication

The digital communication connection is made to the terminals labeled C, and D. Refer to Figure 9 for the appropriate wiring configuration. The drawing shows a system with only one LevelCom 101 digital repeater. The LevelCom 100 can support up to 4 Digital repeaters. The repeaters may be wired in a daisy chain or in a star configuration, parallel to the single device shown in the drawing.

Refer to the LevelCom 100 manual to complete the setup for this kind of installation.

## Relay Output

The LevelCom 101 contains three relays. Relays 1 and 2 are SPDT relays and the third, a horn relay, is SPST with one normally open (NO) contact. The relay contact state is labeled with the relays de-energized.

Note: When relays 1 & 2 are selected as alarm relays they are automatically configured as failsafe. Thus the coils are energized in the normal state and de-energize upon alarm. Therefore, if you require the contact to close upon alarm

then wire to the “Normally Closed” (NC) terminals. Contacts are rated at 5A non-inductive, 120 VAC or 30 VDC. Maximum ratings are 250 VAC/125 VDC/150 W.

## **RS422/RS485 Serial Communications**

Serial communications is a standard feature on the LevelCom 101. The connector is a plug and socket on the back of the case.

The terminals are described below:

[RX-] Receive Data, (-polarity) Connect to Computer [TX-] Transmit Data, (- polarity)

[RX+] Receive Data, (+ polarity) Connect to Computer [TX+] Transmit Data, (+ polarity)

[TX-] Transmit Data, (-polarity) Connect to Computer [RX-] Receive Data, (- polarity)

[TX+] Transmit Data, (+ polarity) Connect to Computer [RX+] Receive Data, (+ polarity)

[GND] Common

Figure 8 shows a 5 wire RS-422 connection. You may instead use a 3 wire RS-485 connection. Refer to Appendix A for wiring diagrams for these interfaces. Both of these interfaces allow multiple devices on the same cable. Simply wire each LevelCom 100 connector as shown in the drawings. The cable is chained from one LevelCom 101 to the next.

## **Contact Inputs**

There are four (4) external contact inputs. The Alarm Acknowledge and Horn Silence functions can be switched externally. The dry contacts are wired to the terminals ACK / GND and HS / GND as shown in figure 3. The other two (2) contact inputs are reserved for future use.

# Basic Programming

The TMS LevelCom 101 Liquid Level Computer is shipped with a default configuration loaded into the configuration memory. This configuration must be changed to reflect the input being monitored. To place a LevelCom 101 in service, only those features which are going to be used need be changed in the program.

Prior to programming please complete the Programming Worksheet found on page 39. The Programming Worksheet contains all user selectable settings and follows the sequence used in programming the LevelCom 101. The minimum requirements for accurate operation in a fresh water tank are Sensor Range, Depth Units, Maximum Depth and Bottom Offset. Fluids other than fresh water also require the Specific Gravity of the fluid to be entered.

Refer to the Configuration Interface Map at the end of this manual. The sensor range must be entered first. Then the logical sequence is to program the spe-

cific gravity, display units, tank table, etc. using the **MODE**, **ESC**, **ENTER**, **UP**, and **DOWN** keys.

## Important Note About Programming

The LevelCom 101 is designed to be "User Friendly". We encourage you to enter into the program, browse through the configuration "tree" and become familiar with data entry, the program flow and the general operation of the unit.

Do not be concerned about changing any values while learning. After exploring the LevelCom 101 configuration interface all feature selections and parameters you have entered can be easily erased and the unit returned to the factory set default settings. To reset the LevelCom 100 to the default condition please follow the steps found on page 19 in Erase All Memory/Reset Factory Defaults. If at any time you encounter difficulties in programming, please contact TMS for assistance.

## Basic Programming Key Functions

Figure 11 shows the buttons as they are seen on the face of the LevelCom101

**MODE:** Places the unit into the Program Mode. It also selects/deselects functions.

**ESC:** Allows a user to back out of a menu item without changing settings.

**UP/DOWN:** Scroll vertically through the menu. They are also used to adjust parameter values.

**ENTER:** Used to enter the next program level, save selections and parameter values.

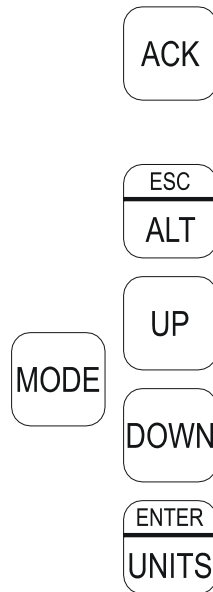

Figure 11 Buttons

## Entering the Program Mode

Press MODE. The “PROGRAM MODE” indicator lamp will light. The unit will display “SYSTEM”. The LevelCom 101 is now in program mode.

**NOTE:** If the unit displays “Enter Password” or “Hot Menu” then the LevelCom has been previously programmed. If the unit displays “Hot Menu” please refer to page 28. If the unit displays ENTER PASSWORD then enter the password or refer to page 28

## Erase All Memory - Reset Factory Defaults

**NOTE:** This operation will remove all selections and parameters from memory and the unit will reset to factory defaults.

1. At SYSTEM, press **UP**. The unit will display UTILITIES.
2. Press **ENTER**. The unit will display COMM SETUP.
3. Press **UP**. The unit will display MEMORY.
4. Press **ENTER**. The unit will display WRITE OVER BACKUP.
5. Press **UP**. The unit will display ERASE ALL MEMORY.
6. Press **ENTER**. The unit will display SURE?
7. Press **ENTER**. The unit will reset and display SYSTEM.

At SYSTEM continue with programming or press ESC to return to operation with factory set defaults. You must enter a minimum configuration for the machine to work correctly. The default sensor range will not match the sensor in the system.

## Programming the Sensor Range

The SENSOR RANGE parameter must be programmed first to enable the LevelCom 101 to correctly configure itself. The input pressure range may be entered in one of three possible units:

- Inches of H2O
  - PSI
  - Kilopascals
1. At SYSTEM press **ENTER**. The unit will display DISPLAY SETUP.
  2. Press **DOWN**. The unit will display SENSOR RANGE.
  3. Press **ENTER**. The unit will display INCHES.
  4. Press **UP/DOWN** to scroll to the desired units for entering sensor range.
  5. Press **ENTER**. The unit will display 0.0 for inched or PSI, 0 for KPa.
  6. Press **UP/DOWN** to scroll to the desired value for the sensor range.
  7. Press **ENTER** to save. SAVING will appear briefly and then shift back to the units selection.
  8. Press **ESC** three times to return to normal operation.

## Programming Specific Gravity

1. At SYSTEM press **ENTER**. The unit will display DISPLAY SETUP.
2. Press **DOWN**. The unit will display SENSOR RANGE.

3. Press **DOWN**. Unit will display SPEC GRAV.
4. Press **ENTER**. Unit will display 1.000.
5. Press **UP/DOWN** to scroll to the specific gravity of the liquid stored in the tank.
6. Press **ENTER** to save the selection. SAVING will appear briefly on the display and the display will shift to SPEC GRAV.
7. Proceed with the next programming step or press **ESC** twice to return to normal operation.

## Programming Display Setup

1. At SYSTEM press **ENTER**. The unit will display DISPLAY SETUP.
2. Press **ENTER**. The unit will display DEPTH UNITS.
3. Press **ENTER**. The unit will display INCHES\*.
4. Press **UP/DOWN** to scroll to the depth unit of measure you have chosen for use.
5. Press **MODE** to select the choice. An asterisk (\*) will appear to the right of the display indicating the item has been selected. If depth is to be displayed in ullage proceed to the next step, if not then proceed to step 7.
6. Press **UP/DOWN** to scroll to ULLAGE. Press **MODE** if you wish depth to be displayed in ullage. An asterisk (\*) will appear to the right of

the display indicating the item has been selected.

7. Press **ENTER** to save the selection(s). SAVING will appear briefly on the display and the display will return to DEPTH UNITS indicating the selection has been recorded.
8. Press **DOWN**. The unit will display VOLUME UNITS.
9. Press **ENTER**. The unit will display NOT USED\*.
10. Press **UP/DOWN** to scroll to the volume unit of measure you have chosen for use.
11. Press **MODE** to select the choice. An asterisk (\*) will appear to the right of the display indicating the item has been selected. If volume is to be displayed in ullage proceed to the next step, if not then proceed to step 13.
12. Press **UP/DOWN** to scroll to ULLAGE. Press **MODE** if you wish volume displayed in ullage.
13. Press **ENTER** to save the selection(s). SAVING will appear briefly on the display and the display will return to VOLUME UNITS indicating the selection has been recorded.
14. Press **DOWN**. The unit will display WEIGHT UNITS.
15. At WEIGHT UNITS press **ENTER**. The unit will display NOT USED\*.
16. Press **UP/DOWN** to scroll to the weight unit of measure you have chosen for use.

17. Press **MODE** to select the choice. An asterisk (\*) will appear to the right of the display indicating the item has been selected. If weight is to be displayed in ullage proceed to the next step, if not then proceed to step 19.

18. Press **UP/DOWN** to scroll to ULLAGE. Press **MODE** if you wish weight displayed in ullage.

19. Press **ENTER** to save the selection. SAVING will appear briefly on the display and the display will return to WEIGHT UNITS indicating the selection has been recorded.

20. Press **DOWN**. The unit will display DISPLAY UNITS.

**NOTE:** DISPLAY UNITS will only appear if either a Volume or Weight unit was selected. In the case of depth only being selected the unit will display TANK TABLE.

21. At DISPLAY UNITS press **UP/DOWN** to scroll to the unit of measure you have chosen for normal display.

**NOTE:** The choice of Display Units will determine the unit of measure the LevelCom will use to set Alarm Set-points later in the programming procedure. It may simplify programming to set the Display Unit as depth until programming has been completed. After the program has been entered you can return to this point in the program and change the display as desired.

22. Press **MODE** to select the choice. An asterisk (\*) will appear to the right

of the display indicating the item has been selected.

23. Press **ENTER** to save the selection. SAVING will appear briefly on the display and the display will return to DISPLAY UNITS indicating the selection has been recorded.

24. Press **DOWN**. The unit will display TANK TABLE.

25. Press **ENTER**. The unit will display MAX DEPTH.

26. Press **ENTER**. The unit will display either the sensor range from the first programming step or a programmed value less than the sensor range.

27. Press **UP/DOWN** to scroll to the maximum vertical dimension of the tank in the Depth Unit of measure you chose in step #5 above.

28. Press **ENTER** to save the value. SAVING will appear briefly on the display and the display will shift to MAX VOLUME or MAX WEIGHT indicating the dimension has been recorded.

**NOTE:** The configuration of the Tank Table is determined by the selection of Weight, Volume and Display Units. If neither Volume nor Weight was selected then the unit will not display MAX VOLUME or MAX WEIGHT and will instead display BOTTOM OFFSET. If this is the case please proceed to step 32.

29. At MAX VOLUME/WEIGHT press **ENTER**. The unit will display 0.0.

30. Press **UP/DOWN** to scroll to the maximum volume/weight of the tank

in the units of measure selected above.

31. Press **ENTER** to save the parameter. SAVING will appear briefly on the display and the display will shift to D9 indicating the selection has been recorded.

**NOTE:** D9 will not appear if a Maximum Volume/Weight is not entered. In this case the unit will display BOTTOM OFFSET. Otherwise press **DOWN** repeatedly until the display shows BOTTOM OFFSET.

**NOTE:** A Tank Table is required to configure the LevelCom 101 to an irregular shaped tank. If this feature is required please refer to Page 29, Advanced Programming for instructions.

32. At BOTTOM OFFSET press **ENTER**. The unit will display 0.0.

33. Press **UP/DOWN** to scroll to the bottom offset distance using the Depth Units you selected in step #5 above.

34. Press **ENTER** to save. SAVING will appear briefly on the display and the display will shift to MAX DEPTH.

35. Press **ESC**. Unit will display TANK TABLE.

36. Proceed with the next programming step or press **ESC** three times to return to normal operation.

## Output Programming - General Description

There are three types of outputs from the LevelCom 101; lights, relays, and

horn. Output programming consists of assigning alarms to the appropriate lights, relays or horn and then entering the setpoints for these alarms. The lights function refers to the HIGH and LOW alarm lights on the front panel. HI HI, HI, LO and LO LO alarms can be assigned to these lights. The relays consist of two SPDT relays. Each relay operation can be assigned to one of three modes:

1. any combination of the HI HI, HI, LO and LO LO alarms
2. a system trouble alarm, or
3. control relay.

A relay assigned to the system trouble alarm cannot be assigned any other alarms. The control function allows the relay to perform a differential level application using one relay. The programming for the control function is described in the advanced programming section of this manual. The horn function is a software alarm selection that drives a SPST normally open relay output. It is assignable to only the HI HI, HI, LO and LO LO alarms.

### Programming Lights

1. At SYSTEM press **DOWN**. Unit will display OUTPUTS.
2. Press **ENTER**. Unit will display LIGHTS.
3. Press **ENTER**. Unit will display HI HI.
4. Press **UP/DOWN** to scroll to the ALARM points you wish to be indicated on the front panel alarm indicator lamps. Press **MODE** to select

choices. An asterisk (\*) will appear to the right of the display indicating the alarm points that have been activated. Select LATCH if you require the alarms to remain even after the level has returned to normal. The ACK button must then be pushed to clear the alarms.

5. Press **ENTER** to save selections. SAVING will appear briefly on the display and the display will shift to LIGHTS.

### Programming Relay Outputs for Alarm

**NOTE:** The following procedure applies to both relay outputs.

1. At SYSTEM press **UP/DOWN** keys to scroll to OUTPUTS.
2. Press **ENTER**. The unit will display LIGHTS.
3. Press the **DOWN** key until unit displays RELAY 1(2).
4. Press **ENTER**. The unit will display ALARM.
5. Press **UP/DOWN** keys to scroll to ALARM, CONTROL, SYS FAIL and LOCAL.
6. Press **MODE** to select the function of the relay. An asterisk (\*) will appear to the right of the display indicating the function has been selected. Also select LOCAL if you choose to have the relay acknowledgeable from the LevelCom front panel **ACK** key.

7. Press **ENTER**. SAVING will appear briefly on the display. If SYS FAIL was selected, press **ESC** to back out of the menu. If ALARM was selected please continue below.

**Note:** If the message OPTION NOT ACTIVE is displayed when you press ENTER at this point it means that no function has been selected for the relay. Go back and select ALARM, CONTROL, or SYS FAIL for the relay and then proceed to the next relevant selection.

**Note:** You can't select LOCAL as an option unless the relay is configured to be an ALARM, or SYS FAIL output.

8. The unit will display HI HI.
9. Press **UP/DOWN** keys to scroll through the menu selections.
10. Press **MODE** key to select those alarms you wish activated.
11. Press **ENTER**. SAVING will appear briefly on the display and the display will shift to RELAY 1 (2).

### Programming Horn Output

1. At SYSTEM press **UP/DOWN** keys to scroll to OUTPUTS.
2. Press **ENTER**. The unit will display LIGHTS.
3. Press the **DOWN** key. The unit will display HORN.
4. Press **ENTER**. The unit will display HI HI.

5. Select those alarms you wish to activate the horn by pressing the **MODE** key. An asterisk (\*) will appear to the right of the display indicating the alarm has been selected. Select LATCH if you require the alarm to remain even after the level has returned to normal. The **ACK** button must then be pushed to clear the alarm.
6. Press **ENTER** to save selections. SAVING will appear briefly on the display and the display will shift to HORN.
7. Press **ESC** to return to normal operation.

### Programming Alarm Setpoints

**NOTE:** Alarm setpoints are adjusted using the Display Units previously selected. For example, if the LevelCom 101 is programmed for depth and weight (e.g. feet/inches and long tons), and is displaying weight, then the alarm setpoints will appear in long tons. At any time you may enter the program and change depth, volume, weight and display units. The LevelCom 101 will automatically convert to the new parameters.

1. At LIGHTS press **UP**. Unit will display ALARM SETPOINTS.
2. Press **ENTER**. Unit will display only those alarms points which were selected as alarm outputs in LIGHTS, HORN or RELAYS 1 and 2.
3. At the displayed alarm (i.e. HI HI) press **ENTER**. Unit will display the depth distance (or calculated vol-

ume/weight at the Bottom Offset distance) specified in Bottom Offset.

4. Press **UP/DOWN** to scroll to the alarm setpoint using the units of measure selected in Display Units.
5. Press **ENTER** to save the selection. SAVING will appear briefly on the display and the display will shift to HI HI HYST.
6. Press **ENTER**. Unit will display 0.0.
7. Press **UP/DOWN** to set the hysteresis. Scroll to the distance from the alarm setpoint you choose to have the alarm condition clear automatically.
8. Press **ENTER** to save the selection. SAVING will appear briefly on the display and the display will shift to the next alarm setpoint.

**NOTE:** Follow steps 3 through 8 for each alarm you have selected.

### Alarm Timeout

An optional alarm timeout may be configured on the LevelCom 101. This can be used to prevent nuisance alarms when the liquid level is near an alarm setpoint. The alarm condition must be present for longer than the configured timeout time before an alarm is triggered. The maximum timeout value is 30 seconds.

1. At LIGHTS press **DOWN** until unit displays ALARM SETPOINTS.
2. Press **ENTER**. Unit will display only those alarm points, which were se-

lected as alarm outputs in Lights, Horn or Relays 1 and 2.

3. Press **UP** or **DOWN** until unit displays TIMEOUT TIME.
4. Press **ENTER**. Unit will display the current timeout value, 0 is the default.
5. Press **UP** or **DOWN** to scroll to the desired alarm timeout value.
6. Press **ENTER** to save the selection. SAVING will appear briefly on the display and the display will shift to TIMEOUT TIME.
7. Press **ESC** three times to return to normal operation.

### Serial Port Setup and Diagnostics

The serial port of the communication interface may be configured for different baud rates and parity settings. These are mostly used for units configured for Modbus communications. The default baud rate is 9600 baud. The default parity setting is N-8-1. These may be changed as needed.

When a group of LevelCom 101s are networked together using a Modbus network, each machine must have a distinct network address. Network communications will not work if two or more machines have the same network address.

1. At SYSTEM press **UP**, the unit will display UTILITIES.
2. Press **ENTER**. The unit will display COMM SETUP.

3. Press **ENTER**. The unit will display NETWORK ADDRESS.
4. Press **ENTER**. The unit will display the current address, the default is 5.
5. Press **UP** or **DOWN** to scroll to the required network address.
6. Press **ENTER** to save the selection. SAVING will appear briefly on the display. The display will return to NETWORK ADDRESS.

The baud rate must agree with the setting in the computer that the LevelCom 100s are connected to. The most common setting is 9600 baud. To set the baud rate use the following procedure.

1. At SYSTEM press **UP**, the unit will display UTILITIES.
2. Press **ENTER**. The unit will display COMM SETUP.
3. Press **ENTER**. The unit will display NETWORK ADDRESS.
4. Press **DOWN**. The unit will display BAUD RATE.
5. Press **ENTER**. This unit will display 1200.
6. Press **UP** or **DOWN** to scroll to the required baud rate. The possibilities are 1200, 2400, 4800, 9600, and 19200.
7. With the desired baud rate showing on the display, press **MENU** to select. An asterisk will show on the right side of the character display.

8. Press **ENTER** to save the selection. SAVING will appear briefly on the display. The display will return to BAUD RATE.

You also need to verify the parity setting of the device you are connecting the LevelCom 100 to. The most common setting is N-8-1, no parity, 8 bits per byte, one stop bit. This will be the normal default for interfacing to desktop computers.

The other settings are often encountered when interfacing to PLCs or data scanners. Some of these devices will not support N-8-1 parity settings. If no parity is used they may operate with the parity bit always set, this will be N-8-2 parity. Alternately they may only support even or odd parity settings. To determine the required setting see the manual for the device you are connecting the LevelCom 101 to.

1. At SYSTEM press **UP**, the unit will display UTILITIES.
2. Press **ENTER**. The unit will display COMM SETUP.
3. Press **ENTER**. The unit will display NETWORK ADDRESS.
4. Press **DOWN** twice. The unit will display PARITY.
5. Press **ENTER**. The unit will display N-8-1.
6. Press **UP** or **DOWN** to scroll to the required parity. The possibilities are N-8-1, N-8-2, EVEN (E-8-1), and ODD (O-8-1).

7. With the desired parity setting showing on the display, press **MODE** to select. An asterisk will show on the right side of the character display.
8. Press **ENTER** to save the selection. **SAVING** will appear briefly on the display. The display will return to **PARITY**.

The LevelCom 101 must be configured to use the Modbus protocol. It may also alternately be configured to use a TMS proprietary protocol using checksums for error detection or not.

1. At **SYSTEM** press **UP**, the unit will display **UTILITIES**.
2. Press **ENTER**. The unit will display **COMM SETUP**.
3. Press **ENTER**. The unit will display **NETWORK ADDRESS**.

4. Press **DOWN** three times. The unit will display **PROTOCOL**.
5. Press **ENTER**. The unit will display **NO CHK**.
6. Press **UP** or **DOWN** to scroll to the required protocol. The possibilities are **NO CHK** for TMS protocol without checksums for error detection, **CHK** for TMS protocol with checksums for error detection, and **MODBUS** for Modbus RTU protocol.
7. With the desired protocol setting showing on the display, press **MODE** to select. An asterisk will show on the right side of the character display.
8. Press **ENTER** to save the selection. **SAVING** will appear briefly on the display. The display will return to **PROTOCOL**.

# Advanced Programming

This section addresses the programming of the more advanced features of the LevelCom 101. These features include setting up a Tank Table, establishing password protection of the LevelCom 101 configuration, setting up a Hot Menu, and the setup of relay outputs. This section assumes the LevelCom 101 has been programmed for basic use. If the unit has not been programmed please refer to page 18, Basic Programming. Use caution as you move through the program. If you inadvertently access a section of the program containing data you do not wish to adjust, simply press ESC to back out to the previous program point. Use the Configuration Flow Chart as you move through the configuration interface.

## Entering the Program Mode

From normal operation press **MODE**. The Program Mode indicator lamp will light. The unit will display SYSTEM.

**NOTE:** If the unit displays ENTER PASSWORD or HOT MENU then the LevelCom 101 has been previously programmed. Confer with the responsible party prior to proceeding. If the unit displays HOT MENU please refer to the following section. If the unit displays ENTER PASSWORD and the password is not available please call TMS for assistance.

## Entering the Program Mode With a Hot Menu Established

The LevelCom 101 program allows the user to establish a Hot Menu which allows access to selectable parameters and functions without the need to enter the program. The Hot Menu feature provides a means to access and adjust commonly used features, e.g. alarm and relay setpoints, specific gravity, etc. without entering into the full program. Items available for the Hot Menu are indicated on the Configuration Flow Chart. For instructions on programming a Hot Menu please turn to page 31. Once programmed, the Hot Menu is instantly accessible from normal operation simply by pressing the **MODE** key. If a Hot Menu is set up, then entering the Program Mode requires some additional steps.

1. From normal operation press **MODE**. Program Mode indicator lamp will light. The unit will briefly display HOT MENU and the display will shift to the first Hot Menu selection.
2. Press the **UP** key. The unit will display CONFIGURE SYSTEM.
3. Press **ENTER**. If no password is required, the unit will display SYSTEM. For information on passwords please see Page 30.

## Tank Table

Accurate depth to volume/weight data is required to calculate the volume and weight of the tanks contents. In regularly shaped tanks, (regular in this case refers to a tank with a linear depth to volume/weight curve), the LevelCom 101 requires only Maximum Depth, Maximum Volume/Weight and Bottom Offset be entered in order to calculate the volume and weight at any depth. If the tank has an irregular shape, e.g. spherical, slanted or curved sides, a hopper bottom, etc., then a Tank Table must be established to ensure accurate volume/weight calculations.

The LevelCom 101 Tank Table allows

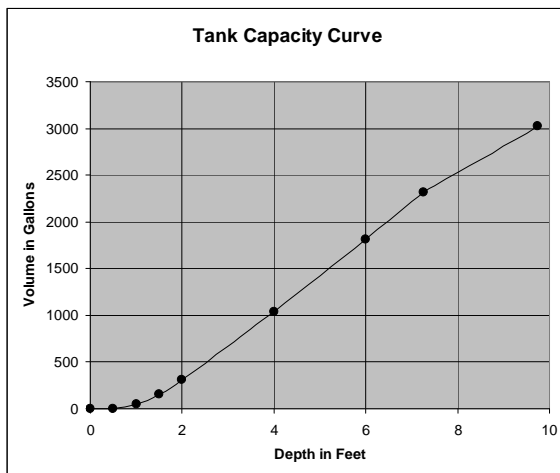

depth ft.	volume gal
9.75	3023
7.25	2321
6	1816
4	1042
2	310
1.5	151
1	44
0.5	4
0	0

Figure 12 Tank Table Example

the user to establish ten (10) vertical levels within the tank that define the shape. The top level is Maximum Depth and Maximum Volume/Weight which defines the total depth and volume/weight when the tank is full. The LevelCom 101 program interpolates linearly between the Tank Table points. Accordingly, as a general rule of thumb, the Tank Table should be designed by placing the points of the Tank Table in the areas with the greatest change. For example, if the tank is a hopper, then the Tank Table points should be concentrated at the bottom. If the tank requires a higher degree of accuracy at the top and bottom, as in a day tank, then concentrate the points at the top and bottom to ensure high accuracy in those areas.

The best source for the tank data can usually be found in the Tank Capacity Curve drawings. While sometimes useful, Sounding Tables must be used with caution. Consider the issues of the sounding tube length, the termination point of the tube and curves in the sounding tubes. The LevelCom 101 measures the pressure exerted by the weight of the column of liquid over the end of the sense line. Using sounding tube data can be misleading, the most common issue being the added length due to curves inside the tank and the tube terminating outside the tank.

The Tank Table can consist of from one to 10 level entries. Use as many levels as you require to achieve the required accuracy. Levels must be entered from the top of the tank working down. TMS recommends the user plot a chart which graphs the depth to volume/weight curve. This provides the best means to determine the points of greatest depth to volume/weight change and the optimum

arrangement for the Tank Table (Figure 12). Transfer this data to the Programming Worksheet for the tank and proceed with the programming instructions below. If you require assistance in establishing the Tank Table please call TMS.

### Programming a Tank Table

1. At SYSTEM press **ENTER**. The unit will display DISPLAY SETUP.
2. Press **ENTER**. The unit will display DEPTH UNITS.
3. Press **UP**. The unit will display TANK TABLE.
4. Press **ENTER**. The unit will display MAX DEPTH.
5. Press **ENTER**. The unit will display the parameter that was assigned during Basic Programming. Confirm that this value is correct and modify if required.
6. Press **ENTER**. The unit will display MAX VOLUME or MAX WEIGHT.
7. Press **ENTER**. The unit will display either 0 or the parameter that was assigned during Basic Programming.
8. If 0 press **UP/DOWN** to scroll to the maximum capacity of the tank. If a parameter has already been established, confirm that the value is correct and proceed to the following step.
9. Press **ENTER** to save the selection. If a new value was assigned SAVING will appear briefly on the

display and the display will shift to D9.

10. Press **ENTER**. The unit will display 0.0.
11. Press **UP/DOWN** to scroll to the depth at point D9 using the Depth Units selected in Basic Programming.
12. Press **ENTER** to save the selection. SAVING will appear briefly on the display and the display will shift to V9 or W9.
13. Press **ENTER**. The unit will display 0.0.
14. Press **UP/DOWN** to scroll to the total tank volume at point #9 using the Volume or Weight Units selected in Basic Programming.
15. Press **ENTER**. SAVING will appear briefly on the display and the display will shift to D8.
16. Repeat steps 11 through 16 for Depth and Volume/Weight levels 8 through 1. After all levels are programmed, the unit will display BOTTOM OFFSET.
17. At BOTTOM OFFSET press **ESC** to return to normal operation or program the bottom offset if not done already.

### Password

Access to the LevelCom 101 program can be restricted by the use of a password. As previously discussed, the LevelCom 101 can be programmed with a user defined Hot Menu which will pro-

vide immediate, non password-protected access to some commonly used features. If a password has been set up the LevelCom 101 will display ENTER PASSWORD whenever an attempt is made to enter into the program mode. The password is entered as described below in Programming a Password steps 4 - 8.

### Programming a Password

1. Press **MODE**. The unit will display SYSTEM.
2. Press **UP/DOWN** to scroll to NEW PASSWORD.
3. Press **ENTER**. The unit will display a flashing \_ cursor.

**NOTE:** The LevelCom 101 password selection consists of the letters A-Z. A password of 1 to 9 characters can be set up.

4. Press **UP/DOWN** to scroll to the first character.
5. Simultaneously press **MODE** and the UP key to shift to the next character. The flashing cursor will shift one character to the right
6. Press **UP/DOWN** to scroll to the second character.
7. Repeat steps five and six until your password is displayed.
8. Press **ENTER**. SAVING will appear briefly on the display and the display will return to NEW PASSWORD indicating your password has been saved.

**NOTE:** This password will be required to enter into the configuration program. TMS recommends you set up a Hot Menu to access those parameters you would like accessible but not password protected. If the password is lost please call TMS for assistance.

### Hot Menu

The LevelCom 101 can be programmed with a Hot Menu feature. This allows the user to set up certain parameters and functions into a menu that is instantly accessible simply by pressing the **MODE** key. This feature is especially helpful if the user has set up password protection. Once the Hot Menu has been programmed the LevelCom 101 will display HOT MENU when the Mode key is pressed. The parameters set up in the Hot Menu are accessible by scrolling with the UP/DOWN keys.

### Programming Hot Menu

1. At SYSTEM press **UP/DOWN** keys to scroll to HOT MENU.
2. Press **ENTER**. The unit will display either an alarm point, or if no alarms are configured SPEC GRAV.
3. Press the **UP/DOWN** keys to scroll through the functions and parameters available for the Hot Menu.
4. Select those functions/parameters you wish displayed in the hot menu by pressing the **MODE** key. An asterisk (\*) will appear to the right of the display indicating the item has been selected.

5. After selecting the Hot Menu items press **ENTER**. SAVING will appear briefly on the display and the display will return to HOT MENU indicating the selections have been recorded.
6. Press **ESC** to return to normal operation.

## Control Relays

When a relay is set up as a control relay there are two setpoints that must be defined; the on setpoint and the off setpoint. The relay will be energized when the level reaches the ON SETPOINT value and the relay will be de-energized when the level reaches the OFF SETPOINT value. This is simple enough but there are other factors to consider before setting the relays up.

The control option was designed with the intent of controlling a pump or a valve to maintain the level of a tank. If such control is to be implemented it is important to consider what will happen in case there is a failure in the system. The LevelCom will de-energize the relay when any system failure condition is indicated. These include sensor input failure, or onboard hardware failures. When any of these conditions occurs, the LevelCom is no longer able to measure the level in the tank and it enters a fault mode and the relays are de-energized. This way the relays go to the same state they would go to if the LevelCom was powered down. It is very important to consider what will happen to the controlled pump or valve in this case. Should the pump run (fail on) or should it shut down (fail off) in this case? If the pump is filling the tank it should probably shut off to avoid over-

flowing the tank. However if the pump is emptying the tank, and the pump can handle continuous operation it might be better for the pump to fail running, again to avoid overfilling the tank. Since the LevelCom relays have form C contacts it is possible to handle all possible combinations.

First it is important to identify the required failure action. This will determine whether to use the normally open contact, or the normally closed contact of the relay. Then the proper setting of the setpoints will result in the desired action. Remember that the relay ON SETPOINT controls where the relay coil is energized, the OFF SETPOINT where the relay coil de-energizes. The function of the required relay contact can make this seem backward.

In the following a pump or valve will be referred to as Device. The word Deactivated will refer to the condition where no electric power is flowing to the Device, Activated will refer to the condition where electric power is flowing to the device.

### Case 1:

Device must fail to a Deactivated condition. Device is to be activated at a high liquid level, Deactivated at a low liquid level. Wire Device to the normally open contacts of the relay. Set ON SETPOINT to the high level, OFF SETPOINT to the low level.

### Case 2:

Device must fail to an Activated condition. Device is to be activated at a high liquid level, Deactivated at a low liquid level. Wire Device to the normally closed contacts of the relay. Set OFF

SETPOINT to the high level, ON SETPOINT to the low level.

**Case 3:**

Device must fail to a Deactivated condition. Device is to be activated at a low liquid level, Deactivated at a high liquid level. Wire Device to the normally open contacts of the relay. Set ON SETPOINT to the low level, OFF SETPOINT to the high level.

**Case 4:**

Device must fail to an Activated condition. Device is to be activated at a low liquid level, Deactivated at a high liquid level. Wire Device to the normally closed contacts of the relay. Set OFF SETPOINT to the low level, ON SETPOINT to the high level.

In any of the above cases it is strongly advised that any failure case generate a remote alarm if the device is operating in an unattended area. The second relay could be configured as a SYS FAIL relay. Set up this way the relay will be normally energized, and de-energized in any system failure case. The output of this relay could be used to operate a warning horn to alert operators to the failure condition.

**Note:** These relays are intended for pilot duty only and may not be rated for the full current of the device they are controlling.

**Programming Control Relays**

**NOTE:** The following procedure applies to both relay outputs.

1. At SYSTEM press **UP/DOWN** keys to scroll to OUTPUTS.

2. Press **ENTER**. The unit will display LIGHTS.

3. Press the **DOWN** key until unit displays RELAY 1(2).

4. Press **ENTER**. The unit will display ALARM.

5. Press **UP/DOWN** keys to scroll to CONTROL.

6. Press **MODE** to select the function of the relay. An asterisk (\*) will appear to the right of the display indicating the function has been selected

7. Press **ENTER**. SAVING will appear briefly on the display. The unit will display ON SETPOINT.

8. Press **ENTER**. The unit will display 0.0

9. Press **UP/DOWN** keys to scroll to the On Setpoint you have defined on your worksheet.

10. Press **ENTER**. SAVING will appear briefly on the display and the display will shift to OFF SETPOINT.

11. Press **ENTER**. The unit will display 0.0.

12. Press **UP/DOWN** keys to scroll to the Off Setpoint you have defined on your worksheet.

13. Press **ENTER**. SAVING will appear briefly on the display and the display will shift to ON SETPOINT.

14. Press **ESC** to return to normal operation.

# Programming Worksheet Explained

This section provides a description of the Programming Worksheet. This worksheet allows the user to analyze the parameters associated with a given tank and to collect the data in a format that follows the programming procedure. The worksheet below contains explanations of the functions of the data, and guidance in the program setup. **Do not fill in this worksheet; it is for explanation purposes only.**

On page 39 you will find a two page Programming Worksheet. Make enough copies of the Programming Worksheet so you will have one full copy for each LevelCom 101. Your worksheets serve as the record of your LevelCom 101 installations and should be kept on file.

At the back of this manual you will find the Configuration Flow Chart. This is a “tree” chart that documents the program flow path. Referencing this chart will help you to understand the operation and flexibility of the LevelCom 101.

<p><b>Programming Worksheet</b></p> <p><b>Tank:</b>_____ <b>Service:</b>_____ <b>Address:</b>_____</p> <p><b>Password:</b>_____</p>
---

## Sensor Range

This is the first parameter to set up. The machine cannot correctly measure the depth without setting up this parameter. Enter the sensor range in inches of water, PSI or KPa. The sensor range may have to be converted from its original units however these three units should cover most situations.

## Display Setup

This section establishes the display functions of the LevelCom 101. Select the depth, volume and weight units desired. If ullage is to be displayed in any of the units selected then also check ullage. Display Units determines the units that will be displayed by the LevelCom 101. In operation, pressing the **ESCAPE** key will scroll the LevelCom 101 display to the next display parameter.

For example, let's say you have selected Feet & Inches, Barrels and Long Tons as units of measure and have selected Volume Units for display. By pressing the **ESCAPE** key, the instrument will momentarily display L TONS and then indicate the tonnage on the digital display. Pressing ESC again will bring up FEET INCHES followed by the depth. This will remain on the display for approximately 20 seconds and will automatically return to the normal volume display in Barrels.

If the tank service is changed, i.e. fuel oil/ballast, simply select the new Display Unit and modify the Specific Gravity as necessary. The LevelCom will automatically convert the parameters.

(Select one in each category. Select Ullage if desired)

**Depth Units:** Inches\_\_\_ Feet\_\_\_ Feet and Inches\_\_\_ Centimeters\_\_\_ Meters\_\_\_ Ullage\_\_\_  
**Volume Units:** Not Used\_\_\_ Gallons\_\_\_ K Gallons\_\_\_ Liters\_\_\_ K Liter\_\_\_ Ullage\_\_\_  
**Weight Units:** Not Used\_\_\_ Short Tons\_\_\_ Long Tons\_\_\_ Metric Tons\_\_\_ Ullage\_\_\_  
**Display Units:** Depth\_\_\_ Volume\_\_\_ Weight\_\_\_

## Specific Gravity

For programming purposes, it is important to use the specific gravity value that was used to establish the sounding or tank data from which the Tank Table data was derived. The specific gravity can be adjusted to the present (or future) contents of the tank after programming is complete. With each update of specific gravity, the LevelCom 101 will recalculate the Tank Table level and weight data and correct the display accordingly.

Specific Gravity: \_\_\_\_\_

## Tank Table

This programming section defines the physical properties of the tank. Use caution when gathering the data for the Tank Table. Remember that the LevelCom 101 (and any other pressure based level indicator) measures the **vertical** pressure of a liquid column. Because of angularity of sounding tubes and the location of the sounding port, sounding tables are often **not** true vertical representations of the tank's depth to volume characteristics. On some ships, we have seen instances where the sounding tables indicate depths greater than the actual depth of the vessel itself. The Tank Capacity Curves, ullage tables or other engineering data are sources for the vertical data required. As a last resort, the data may be found on the scales of the old tank level indicators; however, in most instances the LevelCom 101 is much more accurate than "eyeballing" the scales.

If the depth is the only parameter to be displayed, then you need only program Maximum Depth and Bubbler to Bottom. However, if the tank is non-linear (the cross section changes with depth) and volume and/or weight is to be displayed, then the Tank Table must be programmed.

The multiple levels (Max Depth and D9-D1) in the Tank Table are used to define the depth to volume/weight curve for non-linear tanks. To maximize accuracy of the instrument we recommend a graph of the depth to volume curve be created using a spreadsheet program. **Beginning at the top of the tank and working downward**, set Tank

Table points along the graphed curve. The LevelCom 101 will interpolate a straight line between the points. Use as many points (D9-D1) as are needed to follow the curve as close as possible. Points must be entered from the top (D9) down. Leave unused points blank.

<b>Max Depth:</b> _____ (In Depth Units of measure selected above)		
<b>Max Volume:</b> _____ (In Volume Units selected above)		
OR		
<b>Max Weight:</b> _____ (In Weight Units selected above)		
D9: _____	V9: _____	W9: _____
D8: _____	V8: _____	W8: _____
D7: _____	V7: _____	W7: _____
D6: _____	V6: _____	W6: _____
D5: _____	V5: _____	W5: _____
D4: _____	V4: _____	W4: _____
D3: _____	V3: _____	W3: _____
D2: _____	V2: _____	W2: _____
D1: _____	V1: _____	W1: _____
<b>Bottom Offset</b> _____ (In Depth Units)		

If the LevelCom 101 is being programmed for a tank used for multiple purposes (e.g. fuel oil/ballast) and the instrument will be displaying volume and weight depending on contents (e.g. fuel oil - Barrels, ballast - Long Tons) it is only necessary to enter **either** volume or weight. The LevelCom 101 will automatically convert the Tank Table to track the other parameter when the instrument is reconfigured. To ensure maximum accuracy, we recommend using volume data, if available, for programming the Tank Table.

Bottom Offset is the distance between the sensor location and the bottom of the tank.

<b>Lights:</b> Hi Hi _____ Hi _____ Lo _____ Lo Lo _____ Latch _____
<b>Horn (optional):</b> Hi Hi _____ Hi _____ Lo _____ Lo Lo _____ Latch _____
<b>Relay 1 (optional):</b> (Select one) Alarm__ Control__ System Failure__ Local__
<b>Relay 1 Alarm:</b> (In Display Units) Hi Hi _____ Hi _____ Lo _____ Lo Lo _____
<b>Relay 1 Control:</b> (In Display Units) On Setpoint _____ Off Setpoint _____
<b>Relay 2(optional):</b> (Select one) Alarm__ Control__ System Failure__ Local__
<b>Relay 2 Alarm:</b> (In Display Units) Hi Hi _____ Hi _____ Lo _____ Lo Lo _____
<b>Relay 2 Control:</b> (In Display Units) On Setpoint _____ Off Setpoint _____

## Outputs

Lights refers to the LevelCom front panel alarm lights. If selected, the High Alarm LED will activate on Hi-Hi and Hi alarms. Similarly the Low Alarm LED will activate on Lo Lo and Lo alarms. Horn is a relay with a form A contact installed in the unit that will activate on the selected alarm points.

If Latch is selected, the lights and/or horn will remain activated until the operator presses the **ACK** button. If Latch is not selected, the lights and/or horn will automatically clear once the alarm condition has passed. The relays (1&2) can be configured to activate remote high or low alarms, to perform control functions or to indicate a failure in the LevelCom or sense line.

If Local is selected for the relays, they will respond to the ACK button on the face of the machine.

### **Alarm Setpoints (In Display Units)**

Using the selected Display Units, establish the alarm setpoints and hysteresis. Hysteresis is the distance the level must travel to automatically clear the alarm. For example, if the LevelCom unit is set up to display depth, and the Hi-Hi setpoint is 10' 0.0". With a 6.0" hysteresis, the Hi-Hi alarm will activate on a climbing level at 10'. When the level drops, the alarm will clear at 9' 6.0".

<b>Hi-Hi:</b> Setpoint_____ Hysteresis_____
<b>Hi:</b> Setpoint_____ Hysteresis_____

Hi and Hi-Hi alarms are adjustable between Bubbler to Bottom and 110% Max Depth. This is to allow the user to configure the program to tanks that are often "pressed" or purposely overflowed (e.g. vessel double-bottom fuel tanks).

<b>Lo:</b> Setpoint_____ Hysteresis_____
<b>Lo Lo:</b> Setpoint_____ Hysteresis_____

Lo alarms are adjustable between Bubbler to Bottom and Max Depth.

## Hot Menu

The LevelCom 101 may be programmed with a “Hot Menu” which allows the user to access and change certain program features and parameters without the need to enter into the complete program. Use discretion in setting up the “Hot Menu”, as these selections will not be password protected

Specific Gravity (Manual)___	Display Units___	Display Mode___
Relay 1 Control Setpoints___	Relay 2 Control Setpoints___	
Alarm Setpoints___		

# Programming Worksheet

Tank: \_\_\_\_\_ Service: \_\_\_\_\_ Address: \_\_\_\_\_  
Password: \_\_\_\_\_

Sensor Range in inches H2O \_\_\_\_\_

## Display Setup

**Depth Units:** Inches \_\_\_ Feet \_\_\_ Feet and Inches \_\_\_  
Centimeters \_\_\_ Meters \_\_\_ Ullage \_\_\_

**Volume Units:** Not Used \_\_\_ Gallons \_\_\_ K Gallons \_\_\_ Liters \_\_\_  
K Liters \_\_\_ Cubic Feet \_\_\_ Barrels \_\_\_ Ullage \_\_\_

**Weight Units:** Not Used \_\_\_ Short Tons \_\_\_ Long Tons \_\_\_  
Metric Tons \_\_\_ Ullage \_\_\_

**Display Units:** Depth \_\_\_ Volume \_\_\_ Weight \_\_\_

Specific Gravity: \_\_\_\_\_

## Tank Table

**Max Depth:** \_\_\_\_\_ (In Depth Units of measure selected above)

**Max Volume:** \_\_\_\_\_ (In Volume Units selected above)

OR

**Max Weight:** \_\_\_\_\_ (In Weight Units selected above)

D9: \_\_\_\_\_ V9: \_\_\_\_\_ W9: \_\_\_\_\_

D8: \_\_\_\_\_ V8: \_\_\_\_\_ W8: \_\_\_\_\_

D7: \_\_\_\_\_ V7: \_\_\_\_\_ W7: \_\_\_\_\_

D6: \_\_\_\_\_ V6: \_\_\_\_\_ W6: \_\_\_\_\_

D5: \_\_\_\_\_ V5: \_\_\_\_\_ W5: \_\_\_\_\_

D4: \_\_\_\_\_ V4: \_\_\_\_\_ W4: \_\_\_\_\_

D3: \_\_\_\_\_ V3: \_\_\_\_\_ W3: \_\_\_\_\_

D2: \_\_\_\_\_ V2: \_\_\_\_\_ W2: \_\_\_\_\_

D1: \_\_\_\_\_ V1: \_\_\_\_\_ W1: \_\_\_\_\_

**Bottom Offset:** \_\_\_\_\_ (In Depth Units)

## Outputs

**Lights:** Hi-Hi\_\_\_\_\_ Hi\_\_\_\_\_ Lo\_\_\_\_\_ Lo Lo\_\_\_\_\_ Latch\_\_\_\_\_

**Horn:** Hi Hi\_\_\_\_\_ Hi\_\_\_\_\_ Lo\_\_\_\_\_ Lo Lo\_\_\_\_\_ Latch\_\_\_\_\_

**Relay 1:** (Select one) Alarm\_\_\_ Control\_\_\_ System Failure\_\_\_ Local\_\_\_

**Relay 1 Alarm:** Hi Hi\_\_\_\_\_ Hi\_\_\_\_\_ Lo\_\_\_\_\_ Lo Lo\_\_\_\_\_

**Relay 1 Control:** (In Display Units) On Setpoint\_\_\_\_\_ Off Setpoint\_\_\_\_\_

**Relay 2:** (Select one) Alarm\_\_\_ Control\_\_\_ System Failure\_\_\_ Local\_\_\_

**Relay 2 Alarm:** Hi Hi\_\_\_\_\_ Hi\_\_\_\_\_ Lo\_\_\_\_\_ Lo Lo\_\_\_\_\_

**Relay 2 Control:** (In Display Units) On Setpoint\_\_\_\_\_ Off Setpoint\_\_\_\_\_

## Alarm Setpoints (In Display Units)

**Hi Hi:** Setpoint\_\_\_\_\_ Hysteresis\_\_\_\_\_

**Hi:** Setpoint\_\_\_\_\_ Hysteresis\_\_\_\_\_

**Lo:** Setpoint\_\_\_\_\_ Hysteresis\_\_\_\_\_

**Lo Lo:** Setpoint\_\_\_\_\_ Hysteresis\_\_\_\_\_

## Hot Menu

Specific Gravity (Manual)\_\_\_ Display Units\_\_\_

Display Mode\_\_\_ Relay 1 Control Setpoints\_\_\_ Relay 2 Control Setpoints\_\_\_

Alarm Setpoints\_\_\_

# Troubleshooting

The LevelCom 101 is programmed to monitor certain system functions and to display error messages when abnormal situations are detected. These messages are:

- EEPROM FAILURE
- CURRENT LOOP FAILURE
- DIGITAL COMM FAILURE
- NOT RECEIVING DATA

The following details some of the problems which may be encountered and corrective actions to be taken. **NOTE:** Qualified individuals must perform repairs and troubleshooting.

## **Instrument displays EEPROM FAILURE.**

This message signals the failure of the onboard configuration memory. The EEPROM must be replaced. Consult factory for corrective action.

## **Instrument displays CURRENT LOOP FAILURE.**

No input current is being read by the LevelCom 101. The sensor may have failed or there is a problem with the current loop wiring.

Check the wiring to the sensor and test the sensor to see if it is working correctly.

If the sensor is working correctly and the wiring to the LevelCom 101 is good make sure the plug on the back of the

LevelCom 101 is completely seated. Make sure the screw terminals are tight in the connector, and make sure the wire has been correctly stripped. Sometimes it will look like a wire is correctly clamped in the screw terminal but there is a bit of insulation in the way preventing a good contact.

## **Instrument displays DIGITAL COMM FAILURE.**

The LevelCom 101 is not receiving any signal on the digital communication interface. This message does indicate that the LevelCom 101 detected a digital communication interface board on start up.

First make sure that the LevelCom 100 is correctly set up to send data over a digital communication interface. Make sure there is a digital communication interface installed in the LevelCom 100. If the interface is installed you should see an LED on the interface flashing about two times a second. If this LED is not flashing there is a problem with the digital communication interface board in the LevelCom 100. Make sure the jumpers on the sensor board in the LevelCom 100 are correctly set to ISOLATE. Make sure the wires are hooked to the Analog Output connector, and use Figure 10 to verify that the interface is correctly wired to the LevelCom 101.

If everything in the LevelCom 100 seems to be correct, and its digital

communication module seems to be working check the wiring from the LevelCom 100 to the LevelCom 101 repeater. Check that the screw terminals are tight, and that the wire in the terminals was correctly stripped.

### **Instrument displays NOT RECEIVING DATA.**

The LevelCom is not receiving data over the communication link. The LevelCom 100 is no longer sending data to the LevelCom 101, however data is being sent over the link. In this case the wiring is fine; the problem is in the configuration. Make sure that the addresses are correctly set up. The address in the Digital Communication setup on the LevelCom 100 must match the address set up in the LevelCom 101. If the LevelCom 100 is also communicating over a Modbus interface, its Modbus address cannot match the address of any of the LevelCom 101s on the digital repeater communication interface.

The problem must be a setup problem. If this message is displayed there is valid data on the digital communication interface, but no data is being addressed to the LevelCom 101.

### **Testing relays, displays and buttons.**

The calibrate section of the configuration menu has selections that allow for testing the relays, displays and front panel buttons. Each section is explained below.

The **RELAYS** item gives direct access to cycle the relays. When activated the UP button operates Relay 1, the DOWN button operates Relay 2. The relays de-energize on entering this utility. Press-

ing the appropriate button energizes the associated relay. This is useful for testing the function of the relays and the condition of the relay contacts. It is a useful utility when wiring to external alarm systems or control devices. The ESC key is used to exit this utility.

The **HORN** item is used to test the horn relay. The ENTER button will energize this relay. The ESC key is used to exit this utility.

The **DISPLAY** item is used to test the entire display. When activated the character display will show a rotating pattern that lights all segments in a digit including the decimal point. The UP key will cause the bar graph to light starting from the bottom to the top; the DOWN key will cause the bargraph lights to go out starting from the topmost lit segment down to the bottom. The alarm set-points will remain lit when they are in the dark part of the bar graph, and they will be dark when they are in the lit part of the bar graph. The ESC key is used to exit this utility.

The **BUTTONS** item is used to test the front panel buttons. When active the display will show the name of the last button pressed. This is useful if there is the possibility that one or more of the buttons have failed. Simultaneously press the ENTER key and the ESC key to exit this utility.

### **Modbus Troubleshooting**

If the LevelCom 101 is not communicating on the Modbus interface first check that it is configured to use the Modbus protocol.

After the wiring is verified the next thing to check is the wiring. Verify that the communication interface is wired correctly; use Appendix A as a guide for wiring.

Verify that the Modbus Address is set correctly. See Modbus Communication in the Basic Programming section of this manual.

Verify that the baud rate and parity settings are correct. There are some complications with the parity settings, especially in the case where no parity information is sent. In communications with desktop computers the most common parity setting is N-8-1, no parity, 8 bits per byte, 1 stop bit. In some PLCs though the only available no parity setting is equivalent to N-8-2, no parity, 8 bits per byte, 2 stop bits. When there is a mix up between these types the machines will communicate sometimes, but not reliably, or only in one direction. The second stop bit can sometimes be detected as the start bit of the next byte if an N-8-2 setup is communicating with a N-8-1 setup. This results in framing errors at the receiving end and failed communication. See the Serial Communication section on page 25.

Under the COMM SETUP menu in the UTILITIES menu there is an item called DIAGS. The standard Modbus error counters are accessible here and they can be useful to help troubleshoot Modbus communication problems. The items in this menu are as follows

**EVENT COUNT:** Counts messages sent to the LevelCom 101 that were successfully received and processed.

**EXCEPTION COUNT:** Counts messages sent to the LevelCom 101 that were successfully received that generated exceptions. These are messages that cannot be serviced because of parameters out of bounds, or there is a command that is not supported by the LevelCom 101.

**MESSAGE COUNT:** Counts all messages on the Modbus network, including messages not directed at the LevelCom 101.

**CRC ERROR COUNT:** Counts messages sent to the LevelCom 101 who's calculated CRC did not agree with the CRC in the message. This suggests noise in the network is garbling message traffic. If this counter is counting continuously check the network wiring for faults or bad connections.

**CLEAR COUNTERS:** This utility is used to clear the Modbus counters. This is useful when you start troubleshooting to see what the counters are doing now. If the network has been operating continuously for a long time there may be non-zero count values on the error counters even if the events counted are relatively rare. It is important to know if there is a real problem or not. Clear the counters at the beginning of a troubleshooting session to avoid confusion. The values of the error counters are also remotely readable through the Modbus interface. See the Modbus register map section on page 45

# Appendix A

## Serial Network Wiring Diagrams

The diagrams in this section show the wiring for various RS485 installations. Both 5 wire and three wire networks are supported. See the documentation on the master device for the connections. There is not a standard pinout for 9 pin D subminiature connectors so none is shown here. If you are using a plug in

expansion card in a PC the documentation for the card will show the correct pinout for the connectors.

RS-485 connections may be wired to single nodes or multiple nodes. These drawings show multiple node connections.

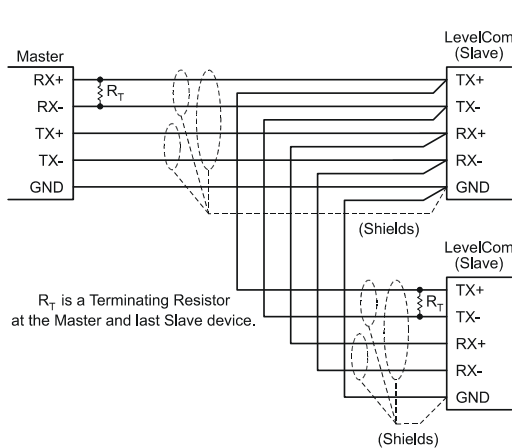

Figure 13 5 wire RS-485 wiring

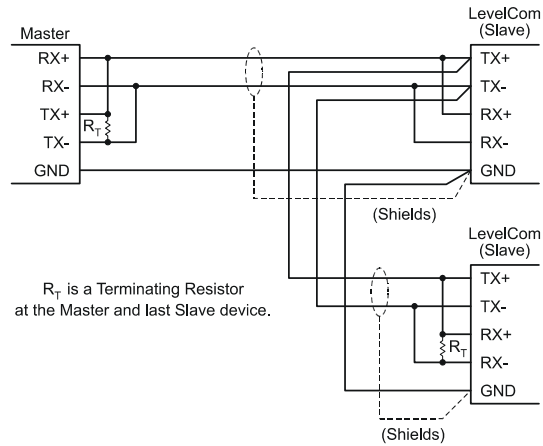

Figure 14 3 wire RS-485 wiring

# Appendix B

## MODBUS Register Values

Following is a map of the input/output registers and coils available in the LevelCom 101 for Modbus communications.

### Read functions:

30001	Level	Level in 0.1 inches
30002	Specific Gravity	Specific Gravity x 1000
30003	Volume (1)	Volume is combined in registers 30003 & 30004 to form a long integer. See note 1 below.
30004	Volume (2)	
30005	Not used	
30006	Status Bits	Status codes as bits. See note 2 below.
30007	Max Depth	Programmed Max Depth in 0.1 inches
30008	HiHi Alarm	HiHi alarm set point in 0.1 inches
30009	Hi	Hi alarm set point in 0.1 inches
30010	Lo	Lo alarm set point in 0.1 inches
30011	LoLo	LoLo alarm set point in 0.1 inches

### The above registers are mirrored in the following holding registers:

40001	Level	Level in 0.1 inches
40002	Specific Gravity	Specific Gravity x 1000
40003	Volume (1)	Volume is combined in registers 30003 & 30004 to form a long integer. See note 1 below.
40004	Volume (2)	
40005	Not used	
40006	Status Bits	Status codes as bits. See note 2 below.
40007	Max Depth	Programmed Max Depth in 0.1 inches
40008	HiHi Alarm	HiHi alarm set point in 0.1 inches
40009	Hi	Hi alarm set point in 0.1 inches
40010	Lo	Lo alarm set point in 0.1 inches
40011	LoLo	LoLo alarm set point in 0.1 inches

### The following coil bits signal various conditions in the LevelCom as noted:

10001	HiHi Alarm	1 = HiHi alarm activated
10002	Hi Alarm	1 = Hi alarm activated
10003	Lo Alarm	1 = Lo alarm activated
10004	LoLo	1 = LoLo alarm activated
10005	Big Number	See note 1 below
10006	Loop failure	1 = 4-20 mA loop failure
10009	EPROM failure	1 = EPROM failure

## Write functions:

Writing values to the following registers allows the specific gravity and alarm set points to be modified remotely. Note that writing to these registers will update the configuration of the LevelCom 101.

The normal value of these registers is 0. A non-zero value in one of these registers causes the LevelCom 101 to update the internal configuration, and after this is done, the LevelCom 101 writes a 0 value back to the register. This return to 0 can be used as a signal that the operation is complete.

40012	Specific Gravity	Specific Gravity x 1000
40013	HiHi Alarm	HiHi alarm set point in 0.1 inches
40014	Hi Alarm	Hi alarm set point in 0.1 inches
40015	Lo Alarm	Lo alarm set point in 0.1 inches
40016	LoLo Alarm	LoLo alarm set point in 0.1 inches

Setting the following coil bits triggers the actions as noted. When the action is initiated by the LevelCom the coil is cleared and reset to "0".

00003	Acknowledge	Allows remote acknowledge for alarm and fault conditions
00004	Restart	Restarts the LevelCom 101

## Notes:

### Base units and Big Number

Level and volume are stored in the LevelCom 101 in specific base units. These values are scaled for display on the LevelCom 101 based on the desired output units. The Modbus data is given only in the base units and must be converted by the user application.

Level is reported by the LevelCom 101 in 0.1 inches. The conversion factors for the other units available in the LevelCom are as follows:

Feet = 0.1 inches / 120  
Centimeters = 0.1 inches x .254  
Meters = 0.1 inches x .00254

Volume is reported by the LevelCom 101 in two possible base units. You must check the Big Number flag in output register 10005. If this coil is set then the base output units are full liters, if the flag is not set the output units are in 0.1 liters. This flag will only be set if an extraordinarily large maximum volume or maximum weight value is input into the Tank Table during the programming of the LevelCom. The default condition is Big Number = 0, volume reported in 0.1 liters.

Assuming Big Number = 0 the conversion factors for the other units available in the LevelCom are as follows:

Gallons = 0.1 liters / 37.85306  
K Gallons = 0.1 liters / 37853.06  
Liters = 0.1 liters / 10  
K Liters = 0.1 liters / 10000  
Cubic Feet = 0.1 liters / 283.1605  
Barrels = 0.1 liters / 1589.829

These conversion factors must be divided by 10 if the Big Number flag is set and the base units are liters.

Volume is a long (32 bit) integer. Since the registers are only 16 bits long the volume is stored in two registers. To get the actual volume registers 30003 and 30004 must be combined in the following way:

$$\text{Volume} = ( (\text{reg } 30003) * 65536 ) + (\text{reg } 30004)$$

#### **Registers 30006 & 40006 - Status Bits**

These registers can be used in place of the 1XXXX coil registers. The bit functions are defined below.

EPROM Failure	0x0001
Loop failure	0x0008
Big Number flag	0x0100
HiHi Alarm	0x8000
Hi Alarm	0x4000
Lo Alarm	0x2000
LoLo	0x1000

# Configuration Interface Map



Portland, Oregon

**LEVELCom 101** LIQUID LEVEL COMPUTER

Program Flow Chart

Version 1.14      10 / 2008

### KEY

**MODE BUTTON**      USED TO ENTER PROGRAM MODE AND SELECT OR DESELECT PARAMETERS

**ESCAPE BUTTON**    EXIT LEFT TO THE PREVIOUS BOX

**ENTER BUTTON**      ADVANCE RIGHT TO THE NEXT BOX WHILE SAVING CHANGES TO THE CURRENT CONFIGURATION

**UP BUTTON**          MOVES UP THROUGH A MENU

**DOWN BUTTON**      MOVES DOWN THROUGH A MENU

   MESSAGE DISPLAYED AT EACH STATION

   WHERE VARIABLES ARE ENTERED WITH UP AND DOWN BUTTONS

\*    MODE BUTTON SETS FLAG TO ACTIVATE OPTION

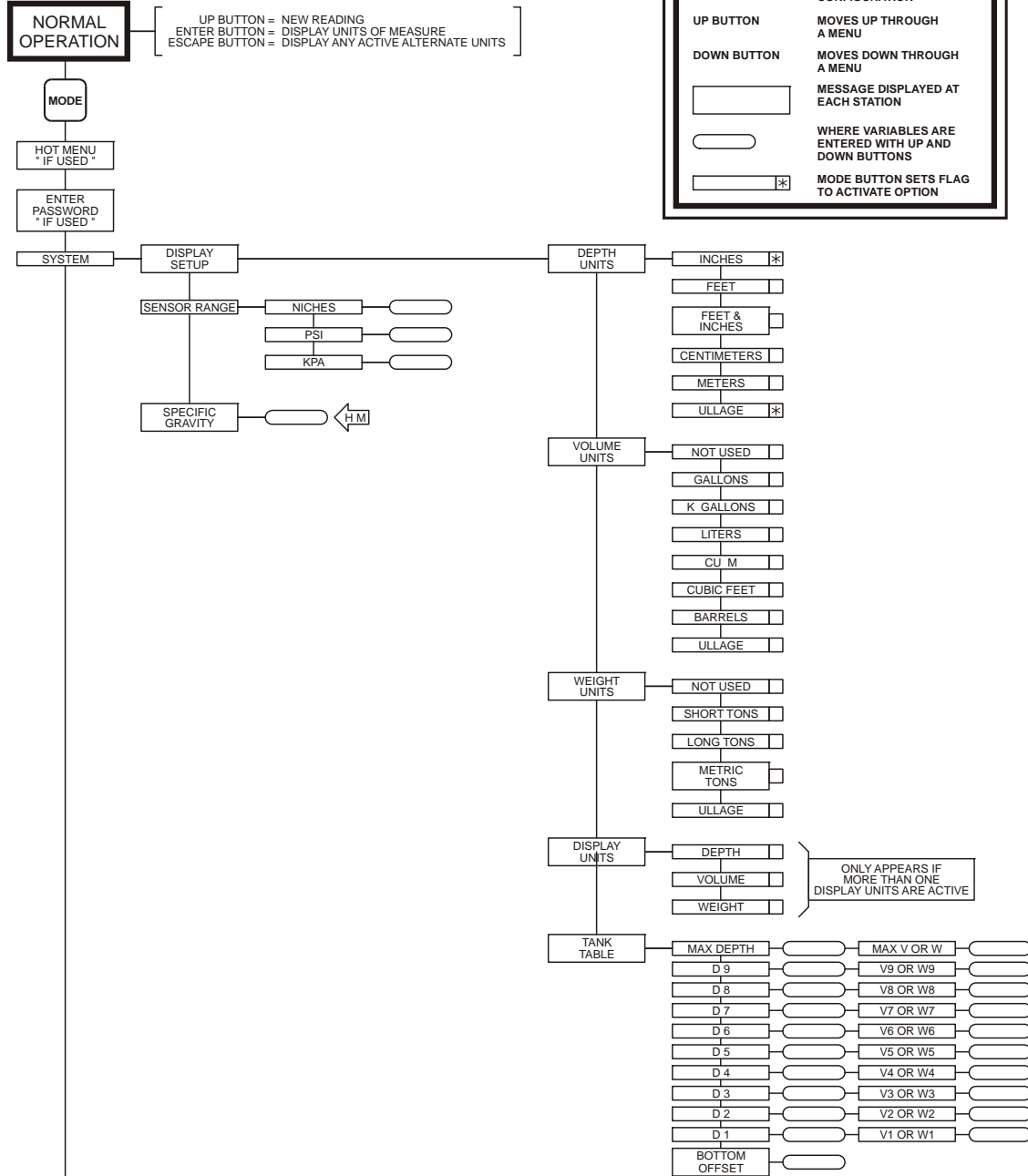

▼ TO PAGE 2

Figure 15 Configuration Interface Map

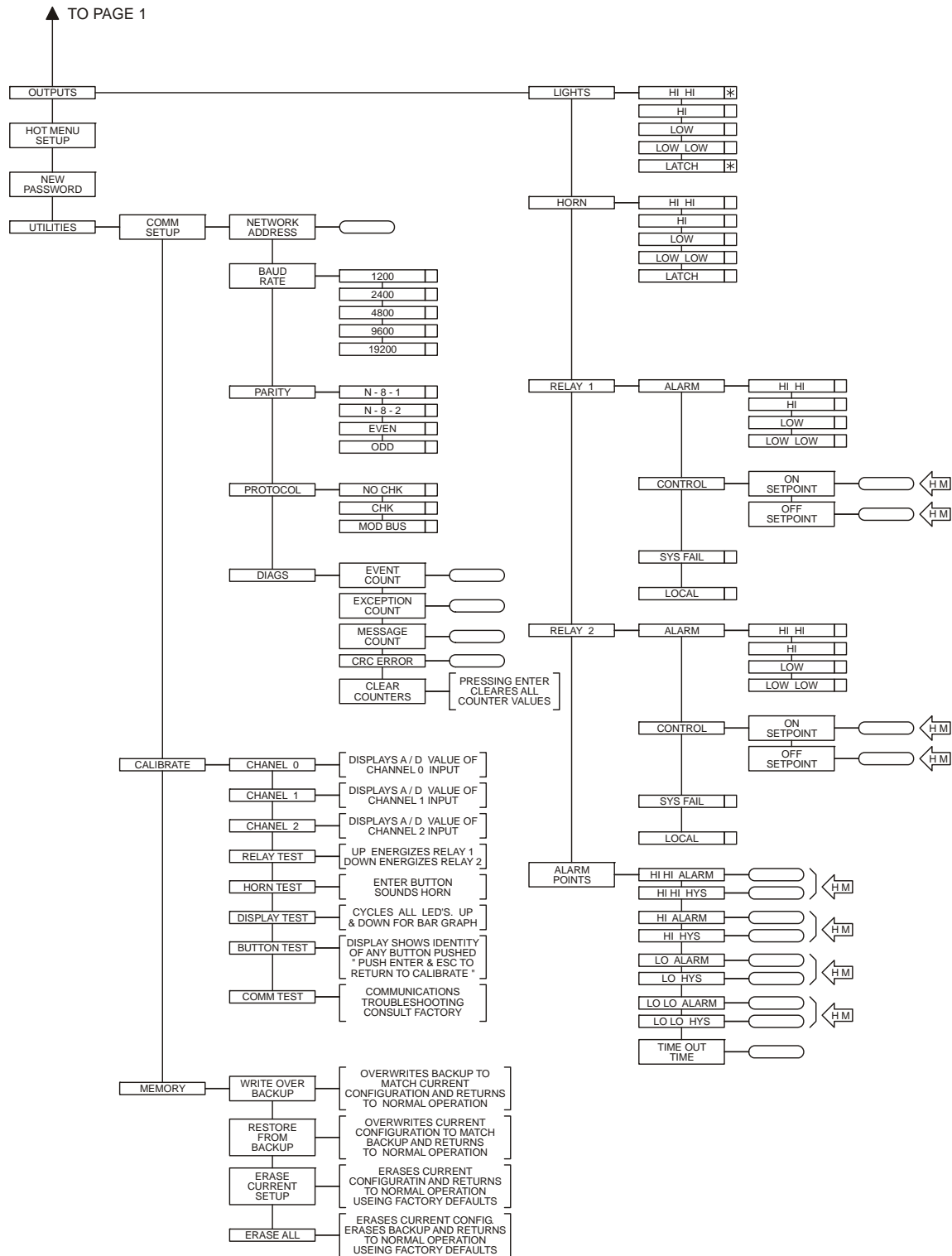

Figure 16 Configuration Interface Map