

LEVEL.COM™ 100 LIQUID LEVEL COMPUTER

INSTRUCTION MANUAL

Version 2.92

TMS, Inc.

6040 N Cutter Circle, Suite 302

Portland, Oregon 97217

Phone: 503-285-8947

Fax: 503-285-1379

Web page: <http://www.tms-usa.com>

email: info@tms-usa.com

Copyright © 2008 Technical Marine Service, Inc.

LevelCom 100 Specifications

Design Standard	The LevelCom 100 has been designed to meet the requirements of 46 CFR 62.25-30 and the American Bureau of Shipping (ABS) 1994 Rules for Building and Classing Steel Vessels, Part 4-Machinery Equipment and Systems.
Approvals	US - UL916 - Process Control Equipment, File E185105 Canada - CUL C22.2 No. 142-1987 ABS Type Approval, Certificate PO16589-X
Power	115VAC / 100mA / 60Hz - Fuse: 2A 24VDC / 500mA – Fuse: 2A
Supply Air	Regulated pressure varies with input sensor range (see below). Filtered to 40 microns
Temperature	Operating range: -10° F to +140° F (-23.33° C to +60° C)
Humidity	5 - 95% RH non-condensing
Enclosure	UL listed as "Rain tight/Indoor use only". NEMA 4 Constructed of .090" 5032 H32 powder coated aluminum alloy. All fasteners are 304 stainless steel
Dimensions	14.5" (37cm) H x 5.5" (14cm) W x 3.8" (9.6cm) D
Alarm Setpoints	Four (4) programmable internal setpoints (Relay option required for remote alarm activation)
Control Setpoints	Four (4) programmable setpoints (Control 1 & 2 On/Off) (Relay option required)
Security	User defined 1 - 9 character password protection
Options	Alarm/control relays: 2 - SPDT "Form C" relays (contacts rated "Pilot Duty") Communications: RS232 / RS422 / RS485 / Modbus RTU Automatic specific gravity compensation Differential Pressure compensation Integral piezoelectric alarm horn Analog output: 4 - 20mA

Tank Sensing Range (H ₂ O)	0 – 31 ft. (9.45m)	0 – 62 ft. (18.9m)	0 – 90 ft. (27.43m)	0 – 180 ft. (54.86m)
Accuracy (Full Scale)	+/-0.2% FS (+/-0.75")	+/-0.2% FS (+/-1.5")	+/-0.2% FS (+/-2.2")	+/-0.1% FS (+/-2.2")
Resolution (Full Scale)	0.1" (2.54mm)	0.2" (5.08mm)	0.3" (7.62mm)	0.3" (7.62mm)
Supply Air Pressure	20 – 35 psi	30 – 50 psi	45 – 60 psi	85 – 100 psi

Table of Contents

LEVELCOM 100 SPECIFICATIONS	2
TABLE OF FIGURES	5
GENERAL INFORMATION	6
FEATURES AND DEFINITIONS	8
DISPLAY FUNCTIONS	11
DIGITAL DISPLAY MESSAGES.....	12
LIGHTS.....	14
BUTTONS.....	14
INSTALLATION	16
CHOOSING A SITE.....	16
MULTIPLE UNIT MOUNTING.....	16
MOUNTING PREPARATION.....	16
THE MOUNTING PACKAGE.....	16
SURFACE MOUNTING.....	16
FLUSH MOUNTING.....	17
THE INTERCONNECT KIT.....	18
ELECTRICAL CONNECTIONS - GENERAL.....	18
ELECTRICAL CONNECTIONS - 120VAC.....	18
ELECTRICAL CONNECTIONS – 24VDC.....	19
ELECTRICAL CONNECTIONS – ANALOG OUTPUT.....	19
ELECTRICAL CONNECTIONS - RELAY OUTPUT.....	20
ELECTRICAL CONNECTIONS - RS-422/485.....	20
SERIAL COMMUNICATION.....	20
PNEUMATIC CONNECTIONS.....	21
BASIC PROGRAMMING	23
BASIC PROGRAMMING KEY FUNCTIONS.....	24
ENTERING THE PROGRAM MODE.....	24
ERASE ALL MEMORY RESET FACTORY DEFAULTS.....	24
DISPLAY SETUP.....	25
SAMPLE AND PURGE TIMING.....	27
SPECIFIC GRAVITY SETUP.....	28
CONFIGURING OUTPUT LIGHTS.....	30
SETTING ALARM SETPOINTS.....	30
ALARM TIMEOUT.....	31
SERIAL PORT SETUP AND DIAGNOSTICS.....	31
ADVANCED PROGRAMMING	34
ENTERING THE PROGRAM MODE.....	34
ENTERING THE PROGRAM MODE WITH A HOT MENU ESTABLISHED.....	34
TANK TABLE EXPLAINED.....	35
PASSWORD.....	36
HOT MENU.....	37
LEVELCOM OUTPUTS.....	38
LIGHTS.....	38

HORN OUTPUT	38
RELAY OUTPUTS	39
PROGRAMMING RELAY OUTPUTS.....	40
ALARM RELAY CONFIGURATION.....	40
CONTROL RELAY CONFIGURATION.....	40
ANALOG OUTPUT	42
CONFIGURE AS A GAUGE OUTPUT	43
SPECIFIC GRAVITY GAUGE OUTPUT SETUP.....	43
CONFIGURE AS A CONTROL OUTPUT.....	44
MANUAL ANALOG OUTPUT	45
DIGITAL COMMUNICATION INTERFACE	46
PROGRAMMING WORKSHEET EXPLAINED.....	48
PROGRAMMING WORKSHEET	53
CALIBRATION	55
PNEUMATIC SENSOR CALIBRATION	55
ANALOG OUTPUT CALIBRATION	57
TROUBLESHOOTING	59
INSTRUMENT DISPLAYS CAN'T ZERO SENSOR.....	59
INSTRUMENT DISPLAYS EEPROM FAILURE.....	60
INSTRUMENT DISPLAYS CHECK AIR.....	61
THE CALIBRATE MENU.....	61
ANALOG OUTPUT TROUBLESHOOTING	63
DIGITAL REPEATER COMMUNICATION TROUBLESHOOTING	63
MODBUS TROUBLESHOOTING	65
THE HARDWARE MENU.....	66
APPENDIX A SERIAL NETWORK WIRING DIAGRAMS.....	69
APPENDIX B MODBUS REGISTER VALUES.....	70
CONFIGURATION INTERFACE MAP	73
SIMPLIFIED CONFIGURATION INTERFACE MAP	74
DETAILED CONFIGURATION INTERFACE MAP	75

Table of Figures

Figure 1 Full tank display	12
Figure 2 Overfill display	12
Figure 3 Overfill and Low Level Arrows	13
Figure 4 Interconnect Kit	18
Figure 5 General Electrical Wiring.....	19
Figure 6 Jumper Settings for -A1 and -A3.....	19
Figure 7 Jumper Settings for LC100-A2 Board	19
Figure 8 Pneumatic Connections	21
Figure 9 Buttons	24
Figure 10 Tank Table Example	35
Figure 11 Bottom View of LevelCom 100	55
Figure 12 LevelCom 100 Interior.....	56
Figure 13 LC100-AO-1 Calibration Potentiometers	57
Figure 14 5 Wire RS-422/485 Wiring.....	69
Figure 15 3 Wire RS-422/485 Wiring.....	69

General Information

Thank you for choosing the LevelCom 100 Liquid Level Computer. You have purchased a refined, high quality and dependable instrument.

The LevelCom 100 incorporates all of the best features available in liquid level gauging today. Developed with the needs of our customers in mind, the LevelCom 100 answers the problems long associated with "bubbler" level sensing technology. By removing the sensor from the tank and combining automatic leak detection, plugged line detection, and automatic "hardware zero" into an easy to use interface, the LevelCom 100 restores this simple, dependable and time proven technology to its rightful place.

The result is a microprocessor-based tank level indicating and process control system, which utilizes pulsed pneumatic (bubbler) depth sensing technology. While the LevelCom 100 has been specifically engineered to replace existing manometer tank gauging systems, it is also outstanding for use in new installations.

For operation, the LevelCom 100 simply requires electrical power, a source of clean, dry air and connection to a sense tube in the tank.

The LevelCom 100 measures the static pressure at the end of the sense line. Using the programmed value for the liquid specific gravity this pressure reading is converted to a depth reading. This raw depth reading is then converted for display in engineering units of measure which include:

- Depth expressed in inches, feet, feet/inches, centimeters or meters
- Volume expressed in gallons, liters, cubic feet or barrels
- Weight expressed in short, long or metric tons

Volume and weight are calculated through a user configured tank curve. Any unit may be displayed in ullage or innage.

The LevelCom 100 calculates the values and displays them on the front panel as 0 to 100% of tank depth on the bar graph indicator and in the desired units of measure (as depth, volume or weight) on the digital display. The instrument is available in four sensor ranges:

- 0 to 31 feet (0 to 9.45 meters)
- 0 to 62 feet (0 to 18.9 meters)
- 0 to 90 feet (0 to 27.4 meters)
- 0 to 180 feet (0 to 54.9 meters)

The LevelCom 100 uses computer controlled solenoid valves, admitting pulses of air to the system only as needed to balance against the liquid level. The unit can be configured for minimal air consumption, for example, in instances where a high-pressure bottle is used as the supply for the operating gas.

Most other pneumatic depth sensing systems work on a continuous air flow principle. This design consumes a constant amount of air regardless of what may be needed to keep the sensing line clear. This means that for maximum accuracy, the air flow-rate must be greater than the fastest rate of anticipated level change. This method wastes compressed air, can

contribute to aeration of the liquid product, and in some cases, liberation of volatile compounds.

When power is applied, the LevelCom 100 performs a diagnostic check of system operations. To ensure accuracy the instrument performs a “**hardware zero**” by sampling the atmospheric air pressure external to the instrument. In normal operation the LevelCom 100 automatically performs the hardware zero at half hour intervals. This eliminates drift of the sensor zero caused by temperature changes in operation.

The LevelCom 100 automatically performs a purge of the sense line at power up. The machine can be configured to purge the sense line regularly at a user-defined frequency ranging from one hour to one week. The user also establishes the duration of the purge with a range from five to 120 seconds. This means the sense line is periodically and automatically cleared of blockages.

Each LevelCom 100 is field programmed with the parameters and feature selections associated with the tank to be monitored. These include:

- Depth in English or metric units
- Volume in gallons, liters, barrels or cubic feet
- Weight in short, long or metric tons
- 10 point Tank Table defining the relation of depth to volume/weight

- Timing of sample and purge cycles
- Manual input of specific gravity
- Four alarm points with hysteresis
- A user defined password
- A **Hot Menu** to access certain user-selectable features without a password

The LevelCom 100 is programmed with a **conversion table** that allows the user to change the selected units of measure (depth, volume and weight) without reprogramming the unit. For example, if the LevelCom 100 is configured to measure depth in feet/inches and later it becomes necessary to change to metric units, the user simply changes the depth unit of measure. The LevelCom 100 will automatically convert the English value and display the correct depth in metric units. Tank table and alarm setpoint units are also automatically converted at the same time.

The LevelCom 100 is **self-diagnostic** and is programmed to detect hardware errors, sense and supply line problems including leaks, plugged lines and high or low supply air pressures. If an abnormal condition is detected, the LevelCom 100 will display the appropriate error message on the digital display and activate an alarm to alert the operator.

The LevelCom 100 is contained in a water-resistant enclosure fabricated of .090" 5052 H32 aluminum alloy.

Features and Definitions

The following are definitions and explanations of LevelCom 100 features and the terminology pertaining to this manual and the LevelCom 100 program.

Alarm Setpoint

A user defined reference point that establishes the point at which a particular alarm will activate.

Bubbler

Refers to the sensing tube installed in the tank and connected to the LevelCom 100. The Bubbler to Bottom parameter is the distance between the lower end of the sense tube and the bottom of the tank.

Buttons

The LevelCom 100 has a set of buttons built into the face plate. These are used to enter the configuration information into the device, and to locally acknowledge alarm conditions. In normal operation the buttons may be used to display alternate units, for example changing from a depth default to read volume or weight. Also the current units may be read.

Calibrate

The LevelCom 100 is shipped fully calibrated and while in operation automatically performs a periodic "hardware zero". Should the unit require field calibration please reference the calibration procedure beginning on page 55.

Communication

The LevelCom 100 can be purchased with optional communication interfaces that allow a group of LevelCom 100s to be networked to a central control or data acquisition computer. These interfaces include RS-422/RS-485 using standard Modbus RTU Protocol. The machine may also be equipped with interfaces for DeviceNet, or Profibus communication networks.

Configuration

The LevelCom 100 program allows users to configure the unit to a wide variety of situations. The unit is shipped with a default configuration and the user adjusts the parameters to match his own requirements thereby establishing the machine configuration.

Demand

The user may configure the LevelCom 100 to perform sample and/or purge functions on demand in lieu of automatic timed cycles. This feature is normally used in areas where the quantity of compressed air is limited or in applications not requiring constant monitoring.

Hardware Zero

The LevelCom 100 periodically checks the sensor for drift of the zero point by measuring atmospheric pressure. This value is used to correct the raw pressure readings from the sense line. In normal operation the LevelCom 100 automatically performs the hardware zero at half hour intervals.

Horn

The LevelCom 100 is available with an optional piezoelectric horn for local alarm indication. This provides a local alarm function, the ACK button is used to acknowledge alarms and silence the horn.

Hot Menu

The hot menu is for use when the configuration will be password protected. It is a configurable menu that allows certain parameters, like specific gravity, to be available to operators who don't have the password. This allows operators to change these parameters as needed while protecting the rest of the configuration from tampering.

Hysteresis

A user-defined measurement between an Alarm Setpoint and the point the alarm condition will automatically clear. For example, assume a tank has a Maximum Depth of 10' 0". The Hi Alarm Setpoint is 8' 0". Hi Hysteresis has been set at 0' 6". The level in the tank must rise to 8' in order for the Hi Alarm to activate. The level must then drop to 7' 6" for the alarm to clear.

Latch

This is a function available in the Light and Horn output sections of the program. Latch holds alarm outputs active, even if the alarm condition has cleared, until the user presses the Acknowledge key.

Lights

Refers to the LevelCom 100 front panel Hi and Lo alarm and status LED indicators.

Local

The optional alarm relays can be configured for Local Acknowledge. In this case if the relays are configured as alarm outputs the alarm output will clear when the ACK button is pressed. Otherwise the relay will clear only when the alarm condition clears.

Menu

The LevelCom 100 configuration is organized as a series of menus. These menus are organized to simplify the configuration process by grouping related parameters together. The buttons on the machine front panel are used to navigate through the menus.

MENU button

The MENU button is the front panel button used to enter the LevelCom 100 configuration menus. The MENU button is also used to make selections and activate or deactivate functions in the configuration. On older machines this button is labeled MODE.

Parameter

A parameter is a number used by the LevelCom 100 to calculate a display value or to trigger an alarm. Parameters are set by the user to define the configuration of the LevelCom 100. Maximum Depth and Bubbler to Bottom are parameters.

Password

The LevelCom 100 can be configured for password protection of the user's configuration. The password characters are the letters A-Z. As few as 1, and as many as 9 characters can be used in the password. The LevelCom 100 can be programmed

with a Hot Menu, which allows easy access to frequently used functions and parameters. The Hot Menu is not password protected.

Programming

When used in this manual this refers to the setup and entry of the user configuration into the LevelCom 100.

Purge

The LevelCom 100 periodically applies compressed air to the sense line to ensure the sense line is free of liquid. This purge can also help keep the end of the sense line clear of obstructions. The LevelCom 100 program can be configured to purge the sense line on demand or at set times. The length of time allowed for a purge is adjustable from 5-120 seconds.

Relays

The LevelCom 100 is available with 2 optional "Form C" relays. These relays can be used for alarm or control purposes.

Sense Line

The sense line is the bubbler tube mounted inside the tank and connected to the LevelCom 100. The LevelCom 100 measures the pressure on this tube to calculate the depth of the liquid in the tank.

Specific gravity

Specific gravity is a user-defined parameter in the program. This parameter is used to convert the static pressure reading from the sense line into a depth reading. Automatic Specific Gravity sensing is available as an option. If the LevelCom 100 is being used to monitor a tank that is used for various products with differing specific gravities then we encourage the user to consider adding this option.

SURE?

"SURE?" appears when the user has entered a section of the program that will erase or overwrite the configuration. The LevelCom 100 queries the user to allow time for the user to consider if he is certain of his actions. If "SURE?" appears on the display at any point in programming and you do not know why - **Don't press ENTER!**

Display Functions

The LevelCom 100 displays depth, volume and weight data in two display formats, a 100-segment vertical bargraph on the left side of the front panel, and a 6-character digital display on the top of the front panel. See Figure 1. There are also individual lights to indicate alarm and fault conditions.

Bargraph: The bargraph indicates **depth only** as a percentage from 0 to 100% of the maximum depth of the tank. Provision for indicating an overflow situation has been included. As an example, if the level of the tank exceeds 100%, the bar graph will continue to indicate the actual depth by flashing the top three segments of the bar graph indicating a level in excess of 100%. The bar graph will display the percentage of overflow by turning off the bar graph from the bottom to indicate the percentage of overflow. See Figure 2.

When the machine is configured for alarms, the setpoint is indicated on the bargraph in the following way. Suppose the maximum depth is set for 20 feet, and the depth measured is 10 feet. The level indicated on the bargraph is 50%. A High Alarm is set for 15 feet of depth, and a Low Alarm is set for 5 feet. A setpoint is indicated by a lit segment in the bargraph if it is above the lit section of the bargraph. The High alarm in this example will show this way at 75%. The setpoint is indicated by a dark segment in the bargraph if the lit section of the bargraph contains the setpoint. The Low alarm in this example will show this way at 25%. If the top of the lit section of the bargraph falls on the segment used to indicate the alarm setpoint value, that segment will flash to indicate

that the level is near the value of the alarm setpoint.

Digital: The digital display indicates depth, volume, or weight, in the units of measure selected during programming. Programming information and error messages are also indicated on the digital display. In normal operation the current display units can be checked by pressing the SHOW UNITS button. When the button is pressed the units will be displayed on the digital character display. The machine may be configured to display more than one unit, depth and volume for example. One of these will be the default display unit. The display can be switched temporarily to the secondary units by pressing the ALTERNATE UNITS button. The name of the units will show briefly and then the display will shift to the alternate units. After approximately 30 seconds the machine will automatically switch back to the default display units.

Important Note

The following section describes the function of the LevelCom 100 in an overflow situation. TMS encourages the user to become familiar with the displays and to use extreme caution when overflowing a tank.

In a standard arrangement, the LevelCom 100 is normally configured to display the tank level on the bargraph indicator as 100% at the maximum depth of the tank ***not*** including standpipes or vents. If the tank is overflowed and liquid enters the piping system above the tank top, the Level-

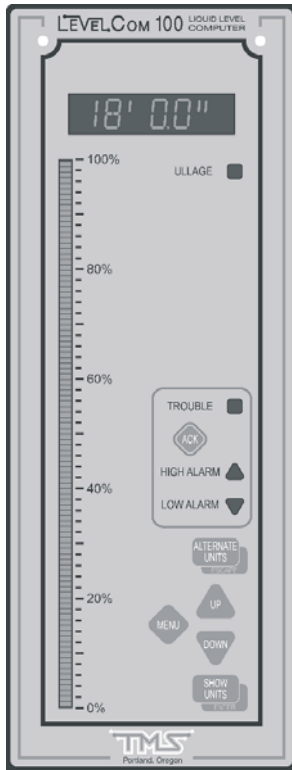

Com 100 will continue to update and display level indications by flashing the top 3 bargraph segments and turning off the bargraph starting at the bottom and moving upward indicating the percent of overfill. In an overfill event depth will be displayed accurately on the digital display and bargraph. Volume and weight are limited to the maximums established in the Tank Table.

Figure 1 Full tank display

Com 100 has been programmed to a tank with a Maximum Depth of 18 feet and a Maximum Volume of 730 bbl. Depth is being indicated on the digital display. Vent and sounding pipes run from the top of the tank to the main deck 12 feet above the top of the tank. The tank is set up to allow cascade filling of adjacent tanks through an overflow line located 5 feet above the top of the tank. Figure 1 shows the digital and bargraph displays at 100% of capacity.

While filling the tank the operator chooses to “press” the tank to ensure a complete fill. During the fill the LevelCom 100 will track the depth and volume accurately to the maximum depth of eighteen feet. At eighteen feet the bargraph will indicate 100% and the digital display will indicate 18' 0.0". As filling continues past this point, the upper three segments of the bar-

Example: Let's assume the Level-

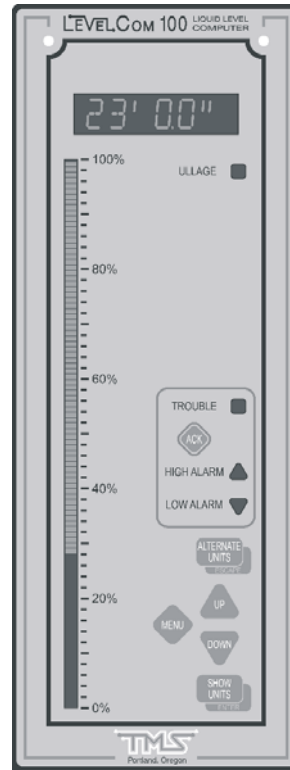

graph will flash indicating a level in excess of 100%. The bargraph will darken at the bottom indicating the percentage of overfill. The digital display will indicate the actual liquid level the unit is sensing. If liquid were pressed five feet up the pipe system the Level-Com 100 will indicate “23' 0.0” on the digital display and 128% on the bargraph. Refer to Figure 2.

Figure 2 Overfill display

If the LevelCom 100 was programmed to display volume or weight then as the depth increases above Maximum Depth the LevelCom 100 will display the Maximum Volume/Weight with an **up arrow** symbol flashing in the left most character of the display indicating the tank volume/weight exceeds the maximum capacity, in this example 730 bbl. The digital display **will not** display a value larger than the programmed Maximum Volume/Weight. The bargraph **will** continue to display accurate depth percentage.

Digital Display Messages

The LevelCom 100 is designed to detect certain system problems and render messages on the digital display. Following is a list of messages, which could be displayed by the LevelCom 100. If an error message occurs refer to the trouble-shooting guide.

LEAK 1

The LevelCom has determined the sense line is leaking. It must be noted the LevelCom will not detect a major, catastrophic failure of the sense line. In this event the LevelCom will sense the ambient atmospheric pressure, calculate that the tank is empty and display the down arrow symbol indicating the level in the tank is below the end of the sense line.

CAN'T ZERO SENSOR

Error message indicating the LevelCom 100 pressure sensor has experienced a problem during a hardware zero measurement. The hardware zero measured is outside the allowable range and the machine may need calibration or repair. The machine will halt operation when this condition occurs, relays will go to their system fail state, and the System Trouble light on the front panel will be lit.

CHECK AIR

Indicates the LevelCom 100 has detected either insufficient or excessive supply air pressure. Confirm the air source is operating at the proper pressure and is available to the instrument (refer to the specifications page 2). Check air supply fittings for tightness. Check for contamination of the air supply, e.g., water accumulations, plugged filters, debris blockages, etc.

Flashing Numeric Display

The numeric display will flash if the LevelCom 100 has sensed a change in level and automatic sampling is not enabled. The instrument is indicating that the displayed data may no longer be correct. Pressing the UP or DOWN key will cause

the unit to sample and display the new reading.

OVER PRESSURE

Indicates the LevelCom 100 is measuring an abnormally high pressure on the sense line. The LevelCom 100 will activate the System Trouble alarm indicator and test the sense line every 30 seconds to see if the condition has cleared. This fault condition will clear when the sense line pressure returns to the allowable range.

SURE?

SURE? appears when the user has entered a section of the program that will erase or overwrite the configuration. The LevelCom 100 queries the user to allow time for the user to consider if he is certain of his actions. If SURE? appears on the display at any point in programming and you do not know why - **Don't press ENTER!**

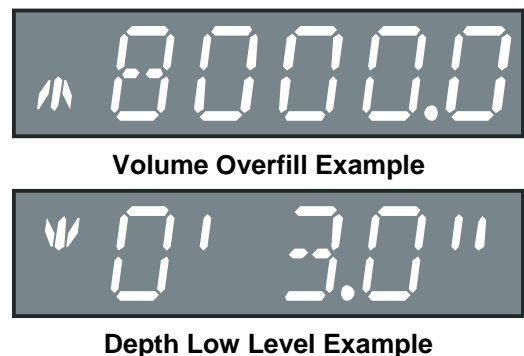

Figure 3 Overfill and Low Level Arrows

Up Arrow or Down Arrow

To indicate an out of range reading the digital display will show flashing arrow symbols in the left most character of the

digital display. When the liquid level falls below the end of the sense line the machine will display the Bubbler to Bottom value with a flashing down arrow to indicate that the fluid level can no longer be measured. If the fluid level rises above the Maximum Depth level the left most character will have a flashing up arrow to indicate that the fluid level is over the top of the tank.

WAIT

Appears when a new reading has been manually requested, as in Flashing Numeric Display above. A new reading is requested by pressing the Up or Down button. When the new reading is complete the display will return to normal showing the new reading.

Lights

On the machine front panel there are individual LED lights to indicate alarm and fault conditions.

The High Alarm and Low Alarm lights are used to indicate existing alarm conditions. There are four possible alarm setpoints available on the machine, High High, High, Low, and Low Low alarm. High and High High alarm conditions are indicated by the High alarm light. Low and Low Low alarm conditions are indicated by the Low Alarm light. When an alarm condition occurs, the respective alarm light will flash to indicate the alarm. If the ACK button is pressed to acknowledge the alarm, the light will quit flashing and remain lit until the alarm condition clears.

The TROUBLE light indicates fault conditions, such as a plugged sense line, low supply air pressure, or leaking sense line.

When the condition occurs, the TROUBLE light will flash to indicate the condition. If the ACK button is pressed to acknowledge the fault, the light will quit flashing and remain lit until the fault condition clears, or another fault condition occurs.

The ULLAGE light is lit to indicate that the current value shown on the digital display is an ullage value, indicating how much of the tank remains to be filled. Typically an ullage reading will indicate 0 for a full tank, and the maximum value for an empty tank.

Buttons

The front panel buttons are used in normal operation to view the display units, to switch temporarily to different display units, to locally acknowledge alarms, and to manually trigger a new reading.

To view the present display units, press the SHOW UNITS button. While the button is pressed the current display units will be shown in text on the digital display, "FEET" for instance.

The machine may be configured with more than one display unit. For instance it might be desired to display depth as FEET, but it is also desired to display the Volume, in BARRELS. In normal operation the machine will display depth information. Press the ALTERNATE UNITS button to display the volume information. The new unit name will be shown briefly on the digital display, BARRELS in this example, and the display will then display the volume information. The display will switch back to the default units automatically after about 30 seconds, or it may be switched back by pressing the ALTERNATE UNITS button again.

To acknowledge alarm and fault conditions, press the ACK button. If an alarm light is flashing to indicate a new alarm condition, the light will stop flashing and remain lit after the ACK button has been pressed.

The machine is configured to sample the sense line regularly. It can be configured to automatically sample the sense line when a change in depth is detected as

well. To conserve air it might be desired to have the machine sample infrequently, and not automatically sample on a change of depth. You can manually trigger a sample any time by pressing the UP or DOWN button while the machine is in normal operation. The display will show the text message WAIT until the new sample operation is complete. Then the machine will display the new reading.

Installation

Choosing a Site

The LevelCom 100 has been designed to be mechanically rugged and well protected against adverse environments, but it is best to select a mounting location that is as clean as possible. Even though the LevelCom 100 enclosure is UL listed as “Rain tight”, try to avoid areas of high moisture and temperature, excessive vibration and concentrated electrical interference. Good lighting is helpful but not essential since the LevelCom 100 display is brightly lit. Consider access for electrical connections to the top and pneumatic tubing to the bottom of the LevelCom 100.

If you are replacing an existing device, you may have an opportunity to improve on the original mounting location. Take a few minutes and study the area to see if another site might be better suited. Some older level indicators did not require any electrical power, so you must be sure that a source of electrical power is accessible. It is best to have a dedicated power supply for the LevelCom 100, that is, one with its own circuit protection device (fuse or circuit breaker).

Multiple Unit Mounting

Many installations require multiple LevelCom 100s to be mounted in close proximity to one another. For the most efficient installation, mount the instruments side by side all at the same level. The LevelCom 100 is exactly 5.5” wide so a 6” center from unit to unit is recommended. A 6” mounting center will afford 0.5” clearance between units. This clearance will allow easier access to mounting hardware should it

become necessary to remove one unit from the installation.

By following the above suggestions, the LevelCom 100 Interconnect Kit can be used to create a wiring path between machines. See page 18 for a drawing and description of the Interconnect Kit.

Mounting Preparation

For access to electrical connections, the LevelCom 100 is designed with two 0.875” holes in each side of the case intended for ½” electrical fittings. Use fittings in accordance with the NEC which are suitable for the wiring system and suitable to maintain the UL “Rain tight” rating of the enclosure.

The Mounting Package

Included with every LevelCom 100 is the following mounting hardware.

2 each - Stainless Steel Mounting Brackets

4 each - #10-32 x ½” Screws for Bracket-to-Case Mounting

Surface Mounting

The LevelCom 100 may be surface mounted by using one of two methods. The first and most common method utilizes the included stainless steel brackets (above), which are first mounted to the back of the case with the four included #10-32 x ½” screws. The brackets are then mounted to the surface using #10 screws. The spacing of the bracket mounting holes is 4” horizontal by 14.75” vertical.

The second method requires that the mounting surface be accessible from the back. Drill four holes in the mounting surface to match the holes in the back of the LevelCom case. The spacing of the holes should be 3" horizontally by 12" vertically. The holes should be sized for clearance of a #10 screw. Then use the included #10-32 x ½" screws and mount the LevelCom 100 directly to the surface. If the surface is too thick to use the included screws, any #10-32 screws will do; however **do not penetrate more than one inch into the LevelCom 100 enclosure.**

Flush Mounting

Flush mounting is accomplished with the optional flush mount kit, which includes 2 stainless steel brackets, 4 - #10-32 x ½" screws and 4 - #10-32 x 1" pointed screws. Cut a 4.75" by 13.5" opening in the mounting surface. Pass the LevelCom 100 through this hole from the front of the panel and then mount the brackets to the rear of the case with the short screws. Insert the pointed screws into the threaded holes in the brackets from the rear, and snug them evenly against the back of the mounting surface. **Do not over tighten the long screws, since this may distort the mounting brackets.**

INTERCONNECT KIT

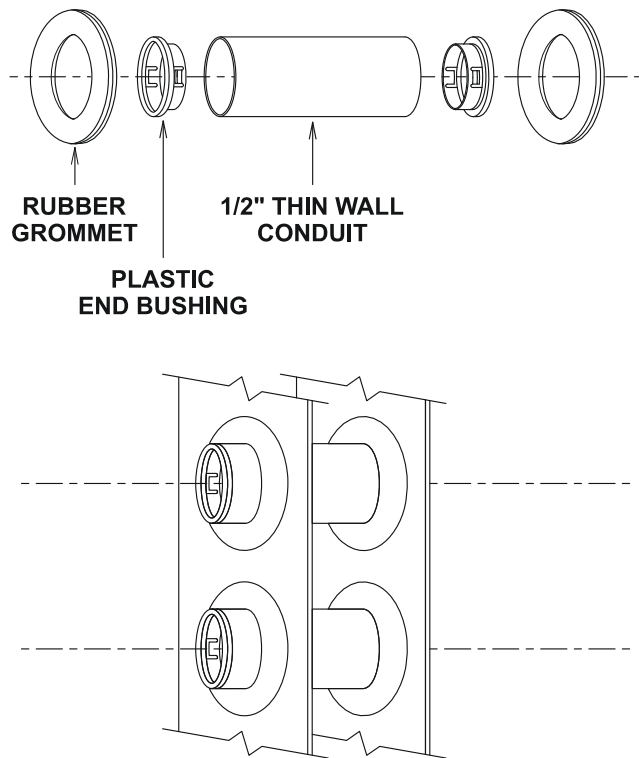

Figure 4 Interconnect Kit

The Interconnect Kit

The LevelCom Interconnect Kit pictured in Figure 4 may be ordered. Each kit contains the following:

- 2 each - 2.5" x 1/2" EMT conduit
- 4 each - Rubber Grommets
- 4 each - Plastic End Bushings

These kits are recommended for installation of several LevelCom 100s side-by-side to simplify electrical connections between instruments. The kits permit a continuous moisture-proof conduit run between units, while allowing individual units to be removed without performing a major disassembly of the conduit system.

After the LevelCom 100s have been mounted at 0.5" or closer spacing, the kits may be installed. If circumstances require a wider spacing simply cut the appropriate length of 0.5" inch EMT. Press the Plastic End Bushings into the EMT. Install the rubber grommets into the holes of the two Side Sealing Plates that are facing each other. Push the EMT through one grommet and into the other. Install the C-clip retainers.

Electrical Connections - General

Depending upon options ordered there are five possible locations for electrical connections in the LevelCom 100. 120 Volt AC power wiring should be separated from any signal or low-voltage control wiring. Generally the 120 Volt AC wires would utilize the upper conduit, and signal or low-voltage wiring, if any, would use the lower conduit. Secure wires with plastic cable ties to the strain relief plate at the top of the enclosure.

Electrical Connections - 120VAC

120 VAC connections are made via the three-point connector labeled **AC POWER** at the top center of the circuit board (See Figure 5). The three-point connector is actually a plug and socket. Grasp the plug firmly and pull it off the board. Note the printing on the circuit board above the socket, which reads [GND] [L1] [L2]. Note the enclosure ground "GND" stud located on the inside of the enclosure, immediately to the right of the 3 capacitors on the main CPU board.

The LevelCom 100 power switch is located to the left of the 120 VAC connector.

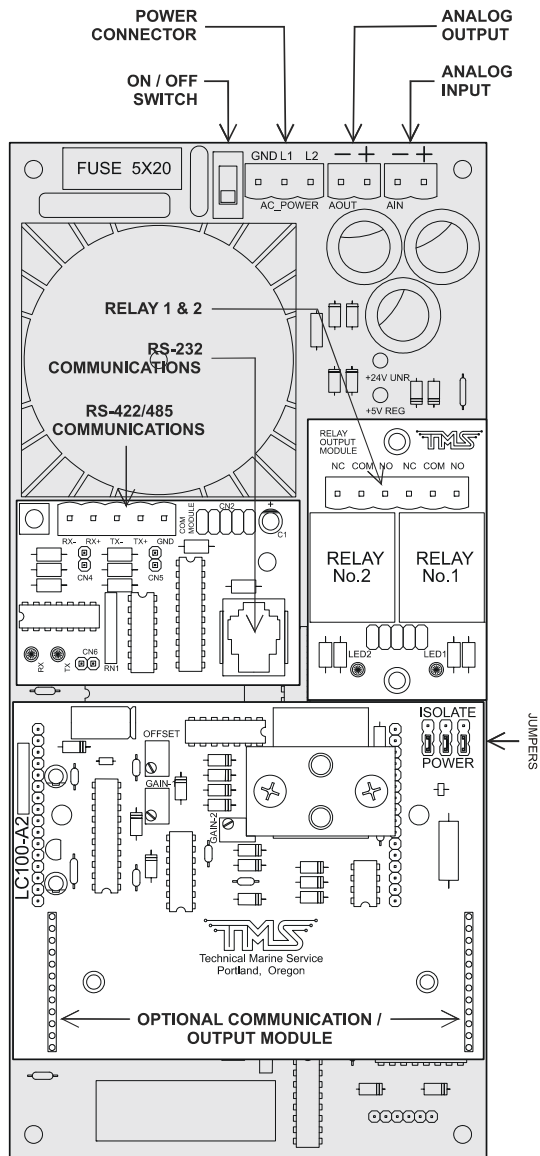

Figure 5 General Electrical Wiring

Power **ON** is the up position (closest to the edge of the board).

Electrical Connections – 24VDC

If your machine is built with the 24VDC input power option the 24VDC power connections are made via the three-point connector labeled **AC POWER** at the top center of the circuit board (See Figure 5). In place of the transformer on the controller circuit board there will be a small circuit

board with a DC to DC converter. There is a label on this circuit board describing the wiring for this option. Note that the GND connection is for system ground and not

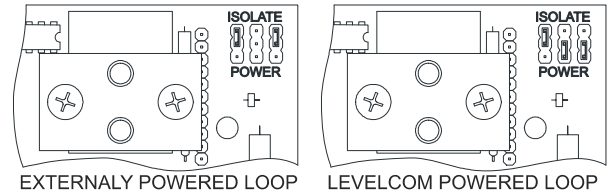

Figure 7 Jumper Settings for LC100-A2 Board

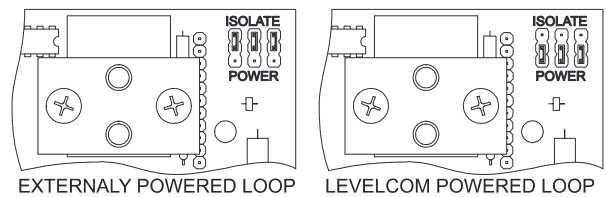

Figure 6 Jumper Settings for -A1 and -A3 the 24V power supply return.

Electrical Connections – Analog Output

The optional Analog Output is a 4-20 mA current type. The output may be internally powered, or isolated and powered from an external source, by changing three circuit board jumpers. External supply voltage may be up to 48 VDC. The jumpers are located on the Analog Circuit Board, (LC100-A1, -A2, -A3) which is the bottom-most board (Figure 5). In the upper right-hand corner of the board (about 5 inches from the bottom of the case) are three small plastic jumpers that have been pushed onto pin headers, note the labels ISOLATE and POWER printed above and below the jumpers (Figure 7 and Figure 6). You must identify the revision of Analog Circuit Board in your machine. The jumper settings are different for different boards. You can read the board type at the left

edge of the Analog Circuit board (Figure 5). Figure 7 and Figure 6 show the jumper positions for the different board types. Move the jumpers as required.

Note: Failure to switch jumpers may cause damage to the circuit board.

The Analog Output connector is located at the top right of the main circuit board adjacent to the Analog Input connector (Figure 5). The connector is a plug and socket. Pull the plug out of the socket for ease in making up the connections. Be sure to observe polarity markings.

Electrical Connections - Relay Output

Since the Relay Output is an option, this connector may not have been installed in your LevelCom 100. If this option has been selected, the six-point connector can be found at the right side of the LevelCom 100 enclosure centered horizontally on the Relay Module (Figure 5).

Note: When facing the relays Relay #1 is on the right, Relay #2 on the left.

The contact arrangements are labeled with the relays de-energized.

NC = Normally Closed

COM = Common

NO = Normally Open

The Relay Outputs are rated for “**Pilot Duty**”. Contacts are rated at 5A non-inductive, 120 VAC or 30 VDC. Maximum ratings are 250 VAC/125 VDC/150 W. It is not recommended that these contacts be used to switch inductive loads. In cases where higher loads need to be switched, an external slave relay rated for the higher

current must be used. After wiring is complete secure the conductors to the wiring support bracket using a cable tie.

Electrical Connections - RS-422/485 Serial Communication

Since Serial Communication is an option, this five-point connector may not have been installed in your LevelCom 100. If this option has been selected, the connector can be found toward the left side of the LevelCom enclosure on the Communications Module. The connector is actually a plug and socket. Note the printing on the circuit board above the socket which reads [RX-] [RX+] [TX-] [TX+] [GND].

The terminals are described below:

1. [RX-] Receive Data (- polarity), Connect to Computer [TX-] Transmit Data (- polarity)
2. [RX+] Receive Data, (+ polarity) Connect to Computer [TX+] Transmit Data, (+ polarity)
3. [TX-] Transmit Data, (- polarity) Connect to Computer [RX-] Receive Data, (- polarity)
4. [TX+] Transmit Data, (+ polarity) Connect to Computer [RX+] Receive Data, (+ polarity)
5. [GND] Common Connect to Computer Common

Twisting the wires together is also recommended; a twisted pair is less likely to pick up or radiate interference.

Serial Communications allows the LevelCom 100 to communicate with a remote computer. All Configuration Parameters

are available to the computer - both to read and to write. The tank level (in 0.1 inch increments) and volume (in 0.1 liter or 1.0 liter increments, depending upon configuration) are readable. System status and alarms are also available. The interface is RS-422/485, which helps to minimize interference, and allows cable runs of up to 500 feet. The LevelCom 100 can be configured to communicate using the Modbus RTU protocol. The baud rate and parity are configurable. Up to 64 LevelCom 100's can be paralleled on one communication cable.

Note: For information on connections at

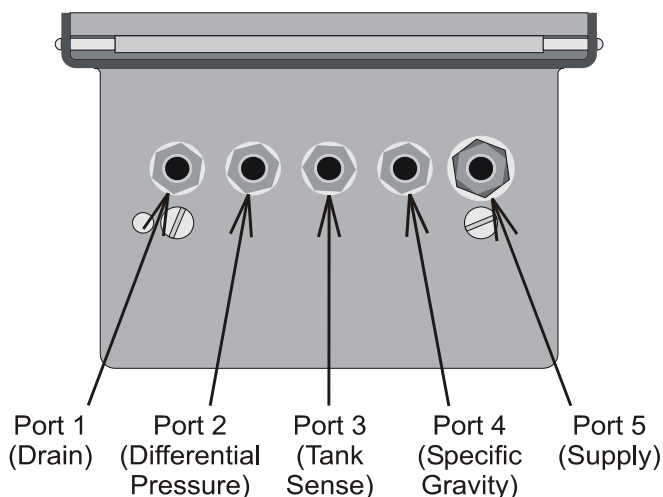

Figure 8 Pneumatic Connections

the computer's serial port, refer to the manual supplied with the computer. There is not one standard pinout for RS-422/485 connections.

Pneumatic Connections

Pneumatic connections are made at the bottom of the LevelCom 100 enclosure. The instrument is supplied with fittings installed as required by the options ordered. Connections are 1/8" female NPT. If it is necessary to install a fitting, thread lubricant should be used sparingly, with great

care taken to keep excess from entering the manifold. Do not use PTFE tape on any pneumatic connections to the LevelCom 100. Fittings should be made up only as tight as necessary to be leak-free. The manifold is aluminum, and can be distorted by using excessive installation force. Small fittings, such as 1/8" NPT do not require much torque to seal well. The pneumatic connection ports are discussed below. In the majority of cases, tubing connections are made only to Port 3, (Tank Sense) and Port 5, (Supply air). See Figure 8.

Port 1 DRAIN is used at regular intervals by the LevelCom 100 to purge its manifold of any water, oil or impurities, and to relieve all pressure to the internal sensor for periodic automatic zero calibration. If desired, the DRAIN connection may be plumbed to a different location, so that when the LevelCom 100 vents, the air will be directed elsewhere. Tubing is to be made up tight and leak free and tubing connections must not obstruct flow or contain any valves. Tubing must be arranged so that the entire run slopes downward to the open end. If liquid can be trapped in this tubing anywhere the hardware zero operation will not work correctly and the machine accuracy will be affected. Use of clear plastic tubing is recommended to aid in seeing possible problems with contaminated air.

Port 2 D.P. (Differential Pressure) is used when the Tank Pressure Compensation option has been specified. It connects to the top of the tank in cases where the tank internal pressure is different from ambient pressure at the LevelCom location. Tubing is to be made up tight and leak free.

Port 3 TANK SENSE connects to the sense line in the tank. Tubing is to be

made up tight and leak free. No valves are to be installed in the sensing line.

Port 4 S. G. (Specific Gravity) connects to a second sense line in the tank, and is used only in applications involving the optional automatic Specific Gravity calculating function. The bottom of the Specific Gravity sense line must be located above the bottom of the Tank Sensing Line (see above), and the exact vertical distance between the bottoms of the two lines must be known and entered into the LevelCom 100 during configuration. Tubing is to be made up tight and leak free.

Port 5 SUPPLY should be connected to a **clean, dry**, source of control air, with the supply pressure set depending upon the specified range of the LevelCom 100 (see

the specifications on page 2). Tubing is to be made up tight and leak-free. The LevelCom 100's design gives it far less susceptibility to contaminated air than pneumatic devices with small orifices but a good filter of 40 microns or less is essential to long-term dependable operation.

The importance of good air quality cannot be overemphasized. Contaminated or wet air can be a source of problems including instrument failure. Be sure that your air supply and associated tubing is in keeping with good pneumatic instrument requirements. In installations where more than one LevelCom is connected to the same air supply, isolation valves for each instrument are recommended.

Basic Programming

100 Liquid Level Computer is shipped with a default configuration loaded into permanent memory. For efficient use of the instrument this configuration must be changed to reflect the tank being monitored. To place a LevelCom 100 in service only those features which are going to be used need be set up.

The minimum requirements for accurate operation in a fresh water tank are Depth Units, Maximum Depth and Bubbler to Bottom. Fluids other than fresh water also require the Specific Gravity of the fluid to be entered. If the tank is used for storage of more than one type of liquid, TMS recommends the Automatic Specific Gravity option be considered.

To avoid confusion and unnecessary programming steps the LevelCom 100 has been designed to confine the program display to only those parameters which have been activated and the options which have been installed. This means that during the programming process you may notice areas in the Configuration Flow Chart (In the back of this manual) that are not displayed in the program. For example, if the optional relay outputs are not installed, then the LevelCom 100 will not display RELAY 1 or RELAY 2. In these instances, the instrument will skip to the next programming step.

The Configuration Flow Chart reflects all of the parameters and options available with the LevelCom 100. If you wish to access a parameter or option, which is not presently available to you, please call TMS for assistance.

Turn to page 48 and read the explanation of how to gather the information you will need for programming of the LevelCom 100. When the worksheet on page 53 has been completed, proceed with programming the instrument.

Important Note About Programming

The LevelCom 100 is designed to be “User Friendly”. We encourage you to enter into the program, browse through the configuration “tree” and become familiar with data entry, the program flow and the general operation of the unit.

Do not be concerned about changing any values while learning. After exploring the LevelCom 100 configuration interface all feature selections and parameters you have entered can be easily erased and the unit returned to the factory set default settings. To reset the LevelCom 100 to the default condition please follow the steps found on page 24 in Erase All Memory/Reset Factory Defaults. If at any time you encounter difficulties in programming, please contact TMS for assistance.

Basic Programming Key Functions

ESCAPE: Allows a user to back out of a menu item without changing settings.

MENU: Places the unit into Program Mode. Also selects/deselects functions.

UP/DOWN: Scroll vertically through the menu. They are also used to adjust parameter values.

ENTER: Used to enter the next program level, save selections and parameter values.

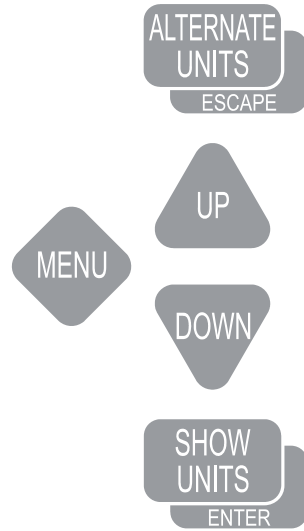

Figure 9 Buttons

Note: Prior to programming it is recommended that the operator complete the Programming Worksheet found on page 53.

The Programming Worksheet contains all user selectable settings and follows the sequence used in programming the LevelCom. Use of the Programming Worksheet will ensure that you will have at your fingertips all of the data required for complete programming of the LevelCom 100. Save the worksheet for your files.

Entering the program mode

1. Open the front cover and power up the LevelCom 100 using the power on/off switch. The unit will initialize and display a numerical value. Close the cover.

2. Press MENU. The unit will display SYSTEM. You are now in the LevelCom configuration interface.

Note: If the unit displays ENTER PASSWORD or HOT MENU then the LevelCom 100 has been previously programmed. Confer with the responsible party prior to proceeding. Note that one of the benefits of the LevelCom 100 is this very ability to modify the configuration at will.

If the unit displays HOT MENU please refer to Page 34. If the unit displays ENTER PASSWORD and the password is not available, please call TMS for assistance.

Erase All Memory Reset Factory Defaults

Note: This section will remove all selections and parameters from memory and the unit will reset to factory defaults. Use this section only if you have previously entered the program and made selections and adjustments you want to delete.

1. At SYSTEM press **UP**, the unit will display UTILITIES
2. Press **ENTER**. The unit will display COMM SETUP.
3. Press **UP**. The unit will display MEMORY.
4. Press **ENTER**. The unit will display WRITE OVER BACKUP.
5. Press **UP**. The unit will display ERASE ALL MEMORY.
6. Press **ENTER**. The unit will display SURE?

7. Press **ENTER**. The unit will reset and display SYSTEM.
8. At SYSTEM continue with programming or press **ESCAPE** to return to operation with factory set defaults.

Display Setup

Note: All descriptions of configuring the display assume that the LevelCom 100 is being configured for the first time after the memory has been erased. If the unit already has an existing configuration the initial numbers seen when entering the Maximum Depth and the Bubbler to Bottom values will be different than described in this procedure.

1. At SYSTEM press **ENTER**. The unit will display DISPLAY SETUP
2. Press **ENTER**. The unit will display DEPTH UNITS.
3. Press **ENTER**. The unit will display INCHES*.
4. Press **UP** or **DOWN** to scroll to the depth unit of measure you have chosen for use.
5. Press **MENU** to select the choice. An asterisk (*) will appear to the right of the display indicating the item has been selected. If depth is to be displayed in ullage proceed to the next step, if not then proceed to step 7.
6. Press **UP** or **DOWN** to scroll to ULLAGE. Press **MENU** if you wish depth to be displayed in ullage. An asterisk (*) will appear to the right of the display indicating the item has been selected.
7. Press **ENTER** to save the selection(s). SAVING will appear briefly on the display and the display will return to DEPTH UNITS indicating the selection has been recorded.
8. Press **DOWN**. The unit will display VOLUME UNITS.
9. Press **ENTER**. The unit will display NOT USED*.
10. Press **UP** or **DOWN** to scroll to the volume unit of measure you have chosen for use.
11. Press **MENU** to select the choice. An asterisk (*) will appear to the right of the display indicating the item has been selected. If volume is to be displayed in ullage proceed to the next step, if not then proceed to step 13.
12. Press **UP** or **DOWN** to scroll to ULLAGE. Press **MENU** if you wish volume displayed in ullage.
13. Press **ENTER** to save the selection(s). SAVING will appear briefly on the display and the display will return to VOLUME UNITS indicating the selection has been recorded.
14. Press **DOWN**. The unit will display WEIGHT UNITS.
15. At WEIGHT UNITS press **ENTER**. The unit will display NOT USED*.
16. Press **UP** or **DOWN** to scroll to the weight unit of measure you have chosen for use.
17. Press **MENU** to select the choice. An asterisk (*) will appear to the right of the display indicating the item has been selected.

lected. If weight is to be displayed in ullage proceed to the next step, if not then proceed to step 19.

18. Press **UP** or **DOWN** to scroll to ULLAGE. Press **MENU** if you wish weight displayed in ullage.

19. Press **ENTER** to save the selection. SAVING will appear briefly on the display and the display will return to WEIGHT UNITS indicating the selection has been recorded.

20. Press **DOWN**. The unit will display DISPLAY UNITS.

Note: DISPLAY UNITS will appear only if either Volume or Weight units were selected. In the case of depth only being selected the unit will display TANK TABLE.

21. At DISPLAY UNITS press **UP** or **DOWN** to scroll to the unit of measure you have chosen for normal display.

Note: The choice of Display Units will determine the unit of measure the LevelCom 100 will use to set Alarm Setpoints later in the programming procedure. It may simplify programming to set the Display Unit as depth until programming has been completed. After the program has been entered you can return to this point in the program and change the display as desired.

22. Press **MENU** to select the choice. An asterisk (*) will appear to the right of the display indicating the item has been selected.

23. Press **ENTER** to save the selection. SAVING will appear briefly on the display and the display will return to DIS-

PLAY UNITS indicating the selection has been recorded.

24. Press **DOWN**. The unit will display TANK TABLE.

25. Press **ENTER**. The unit will display MAX DEPTH.

26. Press **ENTER**. The unit will display the factory default Max Depth (i.e. if feet/inches were selected as the Depth Unit the LevelCom will display 31' 0.0", 62' 0.0" or 90' 0.0" depending on the installed sensor).

27. Press **UP** or **DOWN** to scroll to the maximum vertical dimension of the tank in the Depth Unit of measure you chose in step #5 above.

28. Press **ENTER** to save the dimension. SAVING will appear briefly on the display and the display will shift to MAX VOLUME or MAX WEIGHT indicating the dimension has been recorded.

Note: The configuration of the Tank Table is determined by the selection of Weight, Volume, and Display Units. If neither Volume nor Weight was selected then the unit will not display TANK TABLE and will instead display BUBBLER TO BOTTOM. If this is the case please proceed to step 32.

29. At MAX VOLUME/WEIGHT press **ENTER**. The unit will display 0.

30. Press **UP** or **DOWN** to scroll to the maximum volume/weight of the tank in the units of measure selected above.

31. Press **ENTER** to save the parameter. SAVING will appear briefly on the display and the display will shift to D9 indicating the selection has been recorded.

Note: D9 will not appear if a Maximum Volume/Weight is not entered. In this case the unit will display BUBBLER TO BOTTOM.

Note: A Tank Table is required to configure the LevelCom 100 to an irregular shaped tank. If this feature is required please refer to page 34, Advanced Programming for instructions.

32. At BUBBLER TO BOTTOM press **ENTER**. The unit will display 0.0.

33. Press **UP** or **DOWN** to scroll to the bubbler to bottom distance using the Depth Units you selected in step #5 above.

34. Press **ENTER** to save. SAVING will appear briefly on the display and the display will shift to MAX DEPTH.

Note: If you have installed the Automatic Specific Gravity option then the display will shift to S G DISTANCE.

35. At S G DISTANCE press **ENTER**. Unit will display 0.0.

36. Press **UP** or **DOWN** to scroll to the specific gravity distance using the Depth Units you selected in step #5 above.

37. Press **ENTER** to save. SAVING will appear briefly on the display and the display will shift to MAX DEPTH.

38. Press **ESCAPE**. Unit will display DISPLAY SETUP.

39. Proceed with the next programming step or press **ESCAPE** twice to return to normal operation.

Sample and Purge Timing

The Timing program establishes three parameters. Sample and Purge regulate the frequency of level samples and purge functions. Purge Duration allows the operator to set the amount of time (from 5 to 180 seconds) required for a complete purge of the sense line.

1. At DISPLAY SETUP press **DOWN**. Unit will display TIMING.

2. Press **ENTER**. Unit will display SAMPLE.

3. Press **ENTER**. Unit will display AUTO.

Note: Selecting Auto will force the LevelCom 100 to automatically take a sample whenever a change in level is detected. Auto **and** a predetermined sample interval can be selected at the same time. If the tank being monitored is subject to rolling, Auto will force the LevelCom 100 to chase the level in the tank as the vessel rolls. Consider alarm/control issues when selecting the Auto feature.

4. Press **UP** or **DOWN** to scroll to the sample cycle time you have chosen for use.

5. Press **MENU** to select the choice. An asterisk (*) will appear to the right of the display indicating the item has been selected.

6. Press **ENTER** to save the selection. SAVING will appear briefly on the display and the display will shift to SAMPLE.

7. Press **DOWN**. Unit will display PURGE.

8. Press **ENTER**. Unit will display 1 HR.
9. Press **UP** or **DOWN** to scroll to the purge cycle time you have chosen for use.
10. Press **MENU** to select the choice. An asterisk (*) will appear to the right of the display indicating the item has been selected.
11. Press **ENTER** to save the selection. SAVING will appear briefly on the display and the display will shift to PURGE.
12. Press **DOWN**. Unit will display PURGE DURATION.
13. Press **ENTER**. Unit will display 5 seconds.
14. Press **UP** or **DOWN** to set the purge duration (from 5-180 seconds) you need.
15. Press **ENTER** to save the selection. SAVING will appear briefly on the display and the display will shift to PURGE DURATION.
16. Press **ESCAPE**. Unit will display TIMING.
17. Proceed with the next programming step or press **ESCAPE** twice to return to normal operation.
2. Press **ENTER**. Unit will display 1.000.
3. Press **UP** or **DOWN** to scroll to the specific gravity of the liquid stored in the tank.
4. Press **ENTER** to save the selection. SAVING will appear briefly on the display and the display will shift to SPEC GRAV.
5. Proceed with the next programming step or press **ESCAPE** twice to return to normal operation.

If Automatic Specific Gravity Option is installed there are more items to set up. Use the following procedure to set up for automatic specific gravity operation.

Note: If the Automatic Specific Gravity option is installed the SG DISTANCE parameter must be setup under DISPLAY SETUP (page25). If this parameter is not set up correctly Automatic Specific Gravity will not function.

You can run the LevelCom 100 in either manual or automatic specific gravity. You should set up a manual specific gravity value even if you intend to operate the machine in automatic. On power up the manual value of specific gravity is used initially before the first good specific gravity value is read. Also if there is a problem detected on the specific gravity sense line the LevelCom 100 will revert to manual specific gravity operation. In this case the manual specific gravity value is used.

Specific Gravity Setup

If Automatic Specific Gravity Option is not installed use this procedure.

To set the manual specific gravity value use the following procedure.

1. At TIMING press **DOWN**. Unit will display SPEC GRAV.
1. At TIMING press **DOWN**. Unit will display SPEC GRAV.

2. Press **ENTER**. Unit will display AUTO.
3. Press **DOWN**. Unit will display MANUAL.
4. Press **MENU**. An asterisk (*) will appear to the right of the display indicating the item has been selected.
5. Press **ENTER**. Unit will display the current manual specific gravity value, 1.000 is the default value.
6. Press **UP** or **DOWN** to scroll to the specific gravity of the liquid most likely to be stored in the tank.
7. Press **ENTER** to save the value. SAVING will appear briefly on the display and the display will shift to MANUAL.
8. Proceed with the next programming step or press **ESCAPE** three times to return to normal operation.

With the manual specific gravity value set up use the following procedure to put the LevelCom 100 into the Automatic Specific Gravity mode.

1. At TIMING press **DOWN**. Unit will display SPEC GRAV.
2. Press **ENTER**. Unit will display AUTO.
3. Press **MENU**. An asterisk (*) will appear to the right of the display indicating the item has been selected.
4. Press **ENTER**. Unit will display the current specific gravity value. The LevelCom 100 is now operating in Automatic Specific Gravity mode, however if you just selected this mode in this step the value displayed will initially be the

manual specific gravity value. The LevelCom 100 will have to go through at least one sample operation to update the specific gravity value.

5. press **ESCAPE** three times to return to normal operation.

There is a digital filter that can be set up to reduce noise in the specific gravity reading. Using this filter will slow the LevelCom 100's reaction to changes in the actual specific gravity value though so you should only use the filter value needed. The filter is a simple digital filter that works in the following way. The current specific gravity value is multiplied by the filter value, then the new specific gravity reading is added to this, finally the result is divided by the filter value plus one. As an equation it looks like this:

$$((SGo * Filter) + SGn)/(Filter + 1)$$

SGo is the current value of specific gravity
 SGn is the new specific gravity reading
 Filter is the filter value

A filter value of 0 disables the filter.

To configure the specific gravity filter value use the following procedure.

1. At TIMING press **DOWN**. Unit will display SPEC GRAV.
2. Press **ENTER**. Unit will display AUTO.
3. Press **DOWN** until unit displays FILTER SETUP.
4. Press **ENTER**. Unit will display the current filter value, the default is 0.
5. Press **UP** or **DOWN** to scroll to the desired filter value.

6. Press **ENTER** to save the value. SAVING will appear briefly on the display and the display will shift to DISPLAY SETUP.
7. Press **ESCAPE** three times to return to normal operation.

Configuring Output Lights

This setup assumes that there are no optional outputs installed in the LevelCom 100. See the Advanced Programming section for configuring the optional outputs. This section only describes the alarm lights on the LevelCom 100 front panel.

1. At SYSTEM press **DOWN**. Unit will display OUTPUTS.
2. Press **ENTER**. Unit will display LIGHTS.
3. Press **ENTER**. Unit will display HI HI.
4. Press **UP** or **DOWN** to scroll to the ALARM points you wish to be indicated on the front panel alarm indicator lamps. Press **MENU** to select choices. An asterisk (*) will appear to the right of the display indicating the alarm points that have been activated.

Note: Selection of Latch will disable the automatic clearing of alarms until the user has pressed **ACK**.

5. Press **ENTER** to save selections. SAVING will appear briefly on the display and the display will shift to LIGHTS.

Note: Horn and relay outputs are optional. If these options are installed please refer to page 38 for instructions.

Setting Alarm Setpoints

Note: Alarm setpoints are adjusted using the Display Units previously selected. For example, if the LevelCom 100 is programmed for depth and weight (e.g. feet/inches and long tons), and is displaying weight, then the alarm setpoints will appear in long tons. At any time you may enter the program and change depth, volume, weight and display units. The LevelCom 100 will automatically convert to the new parameters.

1. At LIGHTS press **DOWN** until unit displays ALARM SETPOINTS.
2. Press **ENTER**. Unit will display only those alarm points, which were selected as alarm outputs in Lights, Horn or Relays 1 and 2.
3. At the displayed alarm (i.e. HI HI) press **ENTER**. Unit will display the depth distance (or calculated volume/weight at the Bubbler to Bottom distance) specified in Bubbler to Bottom.
4. Press **UP** or **DOWN** to scroll to the alarm setpoint using the units of measure selected in Display Units.
5. Press **ENTER** to save the selection. SAVING will appear briefly on the display and the display will shift to HI HI HYST.
6. Press **ENTER**. Unit will display 0.0.
7. Press **UP** or **DOWN** to set the hysteresis. Scroll to the distance from the alarm setpoint you choose to have the alarm condition clear automatically.

8. Press **ENTER** to save the selection. SAVING will appear briefly on the display and the display will shift to the next alarm set point.

Alarm Timeout

An optional alarm timeout may be configured on the LevelCom 100. This can be used to prevent nuisance alarms when the liquid level is near an alarm setpoint. The alarm condition must be present for longer than the configured timeout time before an alarm is triggered. The maximum timeout value is 30 seconds.

1. At LIGHTS press **DOWN** until unit displays ALARM SETPOINTS.
2. Press **ENTER**. Unit will display only those alarm points, which were selected as alarm outputs in Lights, Horn or Relays 1 and 2.
3. Press **UP** or **DOWN** until unit displays TIMEOUT TIME.
4. Press **ENTER**. Unit will display the current timeout value, 0 is the default.
5. Press **UP** or **DOWN** to scroll to the desired alarm timeout value.
6. Press **ENTER** to save the selection. SAVING will appear briefly on the display and the display will shift to TIMEOUT TIME.
7. Press **ESCAPE** three times to return to normal operation.

Serial Port Setup and Diagnostics

The serial port of the communication interface may be configured for different baud rates and parity settings. These are mostly

used for machines configured for Modbus communications. The default baud rate is 9600 baud, the default parity setting is N-8-1. These may be changed as needed.

When a group of LevelCom 100s are networked together using a Modbus network, each machine must have a distinct network address. Network communications will not work if two or more machines have the same network address.

1. At SYSTEM press **UP**, the unit will display UTILITIES.
2. Press **ENTER**. The unit will display COMM SETUP.
3. Press **ENTER**. The unit will display NETWORK ADDRESS.
4. Press **ENTER**.
5. Press **UP** or **DOWN** to scroll to the required network address.
6. Press **ENTER** to save the selection. SAVING will appear briefly on the display. The display will return to NETWORK ADDRESS.

The baud rate must agree with the setting in the computer that the LevelCom 100s are connected to. The most common setting is 9600 baud. To set the baud rate use the following procedure.

1. At SYSTEM press **UP**, the unit will display UTILITIES.
2. Press **ENTER**. The unit will display COMM SETUP.
3. Press **ENTER**. The unit will display NETWORK ADDRESS.

4. Press **DOWN**. The unit will display BAUD RATE.
5. Press **ENTER**. This unit will display 1200.
6. Press **UP** or **DOWN** to scroll to the required baud rate. The possibilities are 1200, 2400, 4800, 9600, and 19200.
7. With the desired baud rate showing on the display, press **MENU** to select. An asterisk will show on the right side of the character display
8. Press **ENTER** to save the selection. SAVING will appear briefly on the display. The display will return to BAUD RATE.

You also need to verify the parity setting of the device you are connecting the LevelCom 100 to. The most common setting is N-8-1, no parity, 8 bits per byte, one stop bit. This will be the normal default for interfacing to desktop computers.

The other settings are often encountered when interfacing to PLCs or data scanners. Some of these devices will not support N-8-1 parity settings. If no parity is used they may operate with the parity bit always set, this will be N-8-2 parity. Alternately they may only support even or odd parity settings. To determine the required setting see the manual for the device you are connecting the LevelCom 100 to.

1. At SYSTEM press **UP**, the unit will display UTILITIES.
2. Press **ENTER**. The unit will display COMM SETUP.
3. Press **ENTER**. The unit will display NETWORK ADDRESS.

4. Press **DOWN** twice. The unit will display PARITY.
5. Press **ENTER**. The unit will display N-8-1.
6. Press **UP** or **DOWN** to scroll to the required parity. The possibilities are N-8-1, N-8-2, EVEN (E-8-1), and ODD (O-8-1).
7. With the desired parity setting showing on the display, press **MENU** to select. An asterisk will show on the right side of the character display
8. Press **ENTER** to save the selection. SAVING will appear briefly on the display. The display will return to PARITY.

The LevelCom 100 must be configured to use the Modbus protocol. It may also alternately be configured to use a TMS proprietary protocol using checksums for error detection or not.

1. At SYSTEM press **UP**, the unit will display UTILITIES.
2. Press **ENTER**. The unit will display COMM SETUP.
3. Press **ENTER**. The unit will display NETWORK ADDRESS.
4. Press **DOWN** three times. The unit will display PROTOCOL.
5. Press **ENTER**. The unit will display NO CHK.
6. Press **UP** or **DOWN** to scroll to the required protocol. The possibilities are NO CHK for TMS protocol without checksums for error detection, CHK for

TMS protocol with checksums for error detection, and MODBUS for Modbus RTU protocol.

7. With the desired protocol setting showing on the display, press **MENU** to select. An asterisk will show on the right side of the character display
8. Press **ENTER** to save the selection. **SAVING** will appear briefly on the display. The display will return to **PROTOCOL**.

Advanced Programming

This section addresses the programming of the more advanced features of the LevelCom 100. These features include setting up a Tank Table, establishing password protection of the LevelCom 100 configuration, setting up a Hot Menu, and the setup of optional outputs.

This section assumes the LevelCom 100 has been programmed for basic use. If the unit has not been programmed please refer to page 23, Basic Programming.

Use caution as you move through the program. If you inadvertently access a section of the program containing data you do not wish to adjust, simply press ESC to back out to the previous program point. Following the Configuration Flow Chart as you move through the program will assist you.

Entering the Program Mode

1. From normal operation press **MENU**. The Program Mode indicator lamp will light. The unit will display SYSTEM.

Note: If the unit displays ENTER PASSWORD or HOT MENU then the LevelCom 100 has been previously programmed. Confer with the responsible party prior to proceeding. If the unit displays HOT MENU please refer to the following section. If the unit displays ENTER PASSWORD and the password is not available please call TMS for assistance.

Entering the Program Mode with A Hot Menu established

The LevelCom 100 program allows the user to establish a Hot Menu, which allows access to selectable parameters and functions without the need to enter the program. The Hot Menu feature provides a means to access and adjust commonly used features, e.g., alarm and relay set-points, specific gravity, sample timing, etc. without entering into the full program. Items available for the Hot Menu are indicated on the Configuration Flow Chart. For instructions on programming a Hot Menu please turn to page 37.

Once programmed, the Hot Menu is instantly accessible from normal operation simply by pressing the **MENU** key.

If a Hot Menu is set up, then entering the Program Mode requires some additional steps.

1. From normal operation press **MENU**. Program Mode indicator lamp will light. The unit will briefly display HOT MENU and the display will shift to the first Hot Menu selection.
2. Press the **UP** key. The unit will display CONFIGURE SYSTEM.
3. Press **ENTER**. If no password is required, the unit will display SYSTEM. For information on passwords please see Page 36.

Tank Table Explained

Accurate depth to volume/weight data is required to calculate the volume and weight of the tank's contents. In regularly shaped tanks, (regular in this case refers to a tank with a linear depth to volume/weight curve), the LevelCom 100 requires only Maximum Depth, Maximum Volume/Weight and Bubbler to Bottom be entered in order to calculate the volume and weight at any depth.

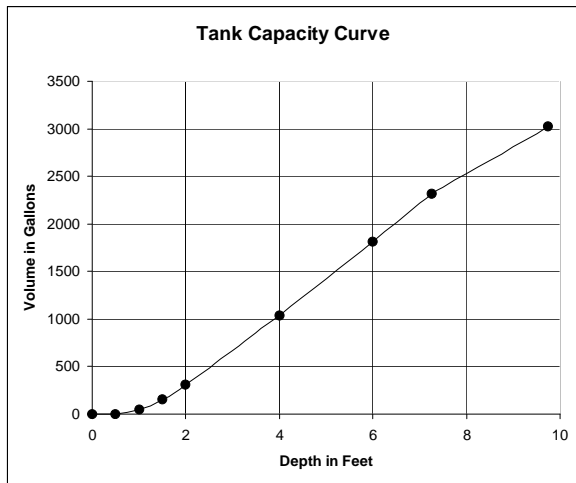

	depth ft.		volume gal
MAX D	9.75	MAX V	3023
D9	7.25	V9	2321
D8	6	V8	1816
D7	4	V7	1042
D6	2	V6	310
D5	1.5	V5	151
D4	1	V4	44
D3	0.5	V3	4
D2	0	V2	0

Figure 10 Tank Table Example

If the tank has an irregular shape, e.g., spherical, slanted or curved sides, a hopper bottom, etc., then a Tank Table must be established to ensure accurate volume/weight calculations. The LevelCom 100 Tank Table allows the user to establish ten (10) vertical levels within the tank

that define the shape. The top level is Maximum Depth and Maximum Volume/Weight, which defines the total depth and volume/weight when the tank is full.

The LevelCom 100 program interpolates linearly between the Tank Table points. Accordingly, as a general rule of thumb, the Tank Table should be established by placing the points of the Tank Table in the areas with the greatest change. For example, if the tank is a hopper, then the Tank Table should be concentrated at the bottom. If the tank requires a higher degree of accuracy at the top and bottom, as in a day tank, then concentrate the points at the top and bottom to ensure high accuracy in those areas.

The best source for the tank data can usually be found in the Tank Capacity Curve drawings. While sometimes useful, we recommend you use **caution** if you are deriving the data from the tank Sounding Tables. Consider the issues of the sounding tube length, the termination point of the tube and curves in the sounding tubes. The LevelCom 100 works off of the pressure exerted by the weight of the column of liquid over the end of the sense line. Using sounding tube data can be misleading, the most common issue being the added length due to curves inside the tank and the tube terminating outside the tank.

The Tank Table can consist of from one to 10 level entries. Use as many levels as you require to achieve your goal. Levels **must** be entered from the top of the tank working down. TMS recommends the user plot a chart, which graphs the depth to volume/weight curve. This provides the best means to determine the points of greatest depth to volume/weight change and the optimum arrangement for the Tank Table (Figure 10). Transfer this data to the Pro-

gramming Worksheet for the tank and proceed with the programming instructions below. If you require assistance in establishing the Tank Table please call TMS.

Programming a Tank Table

1. Enter Program Mode by pressing the **MENU** key.
2. At SYSTEM press **ENTER**. The unit will display DISPLAY SETUP.
3. Press **ENTER**. The unit will display DEPTH UNITS.
4. Press **UP**. The unit will display TANK TABLE.
5. Press **ENTER**. The unit will display MAX DEPTH.
6. Press **ENTER**. The unit will display the parameter that was assigned during Basic Programming. Confirm that this value is correct and modify if required.
7. Press **ENTER**. The unit will display MAX VOLUME or MAX WEIGHT.
8. Press **ENTER**. The unit will display either 0 or the parameter that was assigned during Basic Programming.
9. If 0 press **UP** or **DOWN** to scroll to the maximum capacity of the tank. If a parameter has already been established, confirm that the value is correct and proceed to the following step.
10. Press **ENTER** to save the selection. If a new value was assigned SAVING will appear briefly on the display and the display will shift to D9.
11. Press **ENTER**. The unit will display 0.0.

12. Press **UP** or **DOWN** to scroll to the depth at point D9 using the Depth Units selected in Basic Programming.
13. Press **ENTER** to save the selection. SAVING will appear briefly on the display and the display will shift to V9 or W9.
14. Press **ENTER**. The unit will display 0.0.
15. Press **UP** or **DOWN** to scroll to the total tank volume at point #9 using the Volume or Weight Units selected in Basic Programming.
16. Press **ENTER**. SAVING will appear briefly on the display and the display will shift to D8.
17. Repeat steps 11 through 16 for Depth and Volume/Weight levels 8 through 1. After all levels are programmed, the unit will display BUBBLER TO BOTTOM.
18. At BUBBLER TO BOTTOM press **ESCAPE** to return to normal operation or press **ENTER** to program the Bubbler to Bottom if not done already.

Password

Access to the LevelCom 100 program can be restricted by the use of a password. As previously discussed, the LevelCom 100 can be programmed with a user defined Hot Menu which will provide immediate, non password-protected access to some commonly used features.

If a password has been set up the LevelCom 100 will display ENTER PASSWORD whenever an attempt is made to enter into the program mode. Once the password

has been programmed and the program exited, the password must be used. The password is entered using the same key-strokes as described below in Programming a Password steps 4 - 8.

Programming a Password

1. Press **MENU**. The unit will display SYSTEM.
2. Press **UP** or **DOWN** to scroll to NEW PASSWORD.
3. Press **ENTER**. The unit will display a flashing underline as a cursor.

Note: The LevelCom 100 password selection consists of the letters A-Z. A password of 1 to 9 characters can be set up.

4. Press **UP** or **DOWN** to scroll to the first character.
5. Simultaneously press **MENU** and the UP key to shift to the next character.
6. Press **UP** or **DOWN** to scroll to the second character.
7. Repeat steps five and six until your password is displayed.
8. Press **ENTER**. SAVING will appear briefly on the display and the display will return to NEW PASSWORD indicating your password has been saved.

Note: This password will be required to enter into the configuration program. TMS recommends you set up a Hot Menu to access those parameters you would like accessible but not password protected. **If the password is lost please call TMS for assistance.**

Hot Menu

The LevelCom 100 is programmed with a Hot Menu feature. This allows the user to set up certain parameters and functions into a menu that is instantly accessible simply by pressing the **MENU** key. This feature is especially helpful if the user has set up password protection.

Once the Hot Menu has been programmed the LevelCom 100 will display HOT MENU when the **MENU** key is pressed. The parameters set up in the Hot Menu are accessible by scrolling with the **UP** or **DOWN** keys.

Programming Hot Menu

1. Enter Program Mode by pressing the **MENU** key.
2. At SYSTEM press the **UP** or **DOWN** keys to scroll to HOT MENU.
3. Press **ENTER**. The unit will display the first alarm point activated, HI for example. If no alarms are configured the display will show SPEC GRAV.
4. Press the **UP** or **DOWN** keys to scroll through the functions and parameters available for the Hot Menu.
5. Select those functions/parameters you wish displayed in the hot menu by pressing the **MENU** key. An asterisk (*) will appear to the right of the display indicating the item has been selected.
6. After selecting the Hot Menu items press **ENTER**. SAVING will appear briefly on the display and the display will return to HOT MENU indicating the selections have been recorded.

7. Press **ESCAPE** to return to normal operation.

LevelCom Outputs

The LevelCom 100 has a number of output devices available. The alarm and fault lights in the front panel are always available. In addition there are optional relays that can be configured to function as alarm, or control outputs, an optional horn to give local alarm indication, an optional 4-20 mA output that can be used as a gauge, or control output. The LevelCom 100 can also be equipped with an optional digital communication interface that allows it to communicate with up to four remotely mounted LevelCom 101 Repeaters.

The LevelCom 100 automatically detects any installed optional output devices on power up. The Outputs menu will reflect this. For instance if no relay module is installed in the LevelCom 100 the Relays menu item will not appear in the Outputs menu. Because of this the menus on your machine may not exactly match the menus as shown on the programming interface map at the end of this manual.

To program alarms the alarm points must first be assigned to output devices, lights, relays, or horn. After assigning alarms to outputs the alarm setpoints and hysteresis values can be set. For instance if you have assigned high and low alarms to lights, you will be able to set up the alarm setpoints for these alarms under the Alarm Setpoints menu. You will not be able to set up a setpoint for the High High alarm, or the Low Low alarm though. These alarms have not been assigned to outputs.

Lights

The front panel lights provide a way to locally display fault and alarm status information. If Latch is selected, the alarm lights will remain active until the user presses the ACK key to acknowledge the alarm condition, even if the alarm condition has cleared. If Latch is not selected, then the light will activate only during the alarm event and will automatically clear at the assigned alarm hysteresis.

1. Enter Program Mode by pressing the **MENU** key.
2. At SYSTEM press the **UP** or **DOWN** keys to scroll to OUTPUTS.
3. Press **ENTER**. The unit will display LIGHTS.
4. Press **ENTER**. The unit will display HI HI.
5. Select those alarms you wish to activate the lights by pressing the **MENU** key. An asterisk (*) will appear to the right of the display indicating the alarm has been selected.
6. Press **ENTER** to save the selected alarms. SAVING will appear briefly on the display and the display will return to LIGHTS indicating the selections have been recorded.
7. Press **ESCAPE** to return to normal operation.

Horn Output

The LevelCom 100 has an optional front panel horn output. If you have ordered this feature then the LevelCom 100 will display HORN under the Outputs section of the

program (Please refer to the Configuration Flow Chart). The Horn function allows the user to select which alarms will activate a front panel mounted audible signal. If Latch is selected, the alarm will sound until the user presses the **ACK** key to acknowledge the alarm condition, even if the alarm condition has cleared. If Latch is not selected, then the horn will sound only during the alarm event and will automatically clear at the assigned alarm hysteresis.

Programming Horn Output

1. Enter Program Mode by pressing the **MENU** key.
2. At SYSTEM press the **UP** or **DOWN** keys to scroll to OUTPUTS.
3. Press **ENTER**. The unit will display LIGHTS.
4. Press the **DOWN** key. The unit will display HORN.
5. Press **ENTER**. The unit will display HI HI.
6. Select those alarms you wish to activate the horn by pressing the **MENU** key. An asterisk (*) will appear to the right of the display indicating the alarm has been selected.
7. Press **ENTER** to save the selected alarms. SAVING will appear briefly on the display and the display will return to HORN indicating the selections have been recorded.
8. Press **ESCAPE** to return to normal operation.

Relay Outputs

The LevelCom 100 has two optional "Form C" relay outputs. These relay outputs allow the user to configure the LevelCom 100 to activate external operations, such as, alarms, motor controls, etc. If you have ordered relay outputs then the LevelCom 100 will display RELAY 1 and RELAY 2 under the Outputs section of the program (Please refer to the Configuration Flow Chart).

The relays can be programmed to be either alarm or control outputs. If relays are configured as alarm outputs, they will function similarly to the light or horn outputs. The relays differ from the lights and the horn in that they do not normally respond to the **ACK** button. They normally activate when the alarm condition occurs, and clear at the assigned hysteresis level. Relays cannot be configured to latch. As alarm outputs the relays are intended for interfacing the LevelCom 100 to existing alarm systems.

It is possible to configure an alarm relay to be locally acknowledged. In this case the relay will respond to the **ACK** button. This setup can be used to build a local alarm system for a group of LevelCom 100s. The relay outputs from each LevelCom 100 can be paralleled to run an alarm horn. To silence the horn, the **ACK** button must be pressed on the LevelCom 100 which is generating the alarm.

When a relay is configured as a System Failure relay, it will respond only to failure conditions, such as Sense Line Plugged, Sense Line Leak, and so on.

Programming Relay Outputs

Note: The following procedure applies to both relay outputs. Follow the same procedure for Relay 2.

Alarm Relay Configuration

Follow these instructions to set up a relay for ALARM or SYS FAIL operation.

1. Enter Program Mode by pressing the **MENU** key.
2. At SYSTEM press the **UP** or **DOWN** keys to scroll to OUTPUTS.
3. Press **ENTER**. The unit will display LIGHTS.
4. Press the **DOWN** key until unit displays RELAY 1.
5. Press **ENTER**. The unit will display ALARM.
6. Press the **UP** or **DOWN** keys to scroll to ALARM, or SYS FAIL .
7. Press **MENU** to select the function of the relay. An asterisk (*) will appear to the right of the display indicating the function has been selected. Also select LOCAL if you choose to have the relay acknowledgeable from the LevelCom 100 front panel **ACK** key.
8. Press **ENTER**. SAVING will appear briefly on the display. If SYS FAIL was selected press **ESCAPE** to back out of the menu. If ALARM was selected please continue below.
9. The unit will display HI HI.

10. Press the **UP** or **DOWN** keys to scroll through the menu selections.

11. Press **MENU** key to select those alarms you wish activated.

12. Press **ENTER**. SAVING will appear briefly on the display and the display will shift to ALARM.

13. Press **ESCAPE** to return to normal operation.

Control Relay Configuration

When a relay is set up as a control relay there are two setpoints that must be defined; the on setpoint and the off setpoint. The relay will be energized when the level reaches the ON SETPOINT value and the relay will be de-energized when the level reaches the OFF SETPOINT value. This is simple enough but there are other factors to consider before setting the relays up.

The control option was designed with the intent of controlling a pump or a valve to maintain the level of a tank. If such control is to be implemented it is important to consider what will happen in case there is a failure in the system. The LevelCom 100 will de-energize the relay when any system failure condition is indicated. These include supply air failure, plugged sense lines, or onboard hardware failures. When any of these conditions occurs, the LevelCom 100 is no longer able to measure the level in the tank and it enters a fault mode and the relays are de-energized. This way the relays go to the same state they would go to if the LevelCom 100 lost power.

It is very important to consider what will happen to the controlled pump or valve in this case. Should the pump run (fail on) or

should it shut down (fail off) in this case? If the pump is filling the tank it should probably shut off to avoid overflowing the tank. However if the pump is emptying the tank, and the pump can handle continuous operation it might be better for the pump to fail running, again to avoid overfilling the tank. Since the LevelCom 100 relays have form C contacts it is possible to handle all possible combinations.

First it is important to identify the required failure action. This will determine whether to use the normally open contact, or the normally closed contact of the relay. Then the proper setting of the setpoints will result in the desired action. Remember that the relay ON SETPOINT controls where the relay coil is energized, the OFF SETPOINT where the relay coil de-energizes. The function of the required relay contact can make this seem backward.

In the following a pump or valve will be referred to as Device. The word Deactivated will refer to the condition where no electric power is flowing to the Device, Activated will refer to the condition where electric power is flowing to the device.

Case 1:

Device must fail to a Deactivated condition. Device is to be Activated at a high liquid level, Deactivated at a low liquid level.

Wire Device to the normally open contacts of the relay. Set ON SETPOINT to the high level, OFF SETPOINT to the low level.

Case 2:

Device must fail to an Activated condition. Device is to be activated at a high liquid level, deactivated at a low liquid level.

Wire Device to the normally closed contacts of the relay. Set OFF SETPOINT to the high level, ON SETPOINT to the low level.

Case 3:

Device must fail to a Deactivated condition. Device is to be activated at a low liquid level, Deactivated at a high liquid level.

Wire Device to the normally open contacts of the relay. Set ON SETPOINT to the low level, OFF SETPOINT to the high level.

Case 4:

Device must fail to an Activated condition. Device is to be activated at a low liquid level, Deactivated at a high liquid level.

Wire Device to the normally closed contacts of the relay. Set OFF SETPOINT to the low level, ON SETPOINT to the high level.

Important Note:

In any of the above cases it is strongly advised that any failure case generate a remote alarm if the device is operating in an unattended area. The second relay could be configured as a SYS FAIL relay. Set up this way, the relay will be normally energized, and de-energized in any system failure case. The output of this relay could be used to operate a warning horn to alert operators to the failure condition.

1. Enter Program Mode by pressing the **MENU** key.
2. At SYSTEM press the **UP** or **DOWN** keys to scroll to OUTPUTS.

3. Press **ENTER**. The unit will display LIGHTS.
4. Press the **DOWN** key until unit displays RELAY 1.
5. Press **ENTER**. The unit will display ALARM.
6. Press the **UP/DOWN** keys to scroll to CONTROL.
7. Press **MENU** to activate the Control option. An asterisk (*) will appear to the right of the display indicating the function has been selected. Press **ENTER**.
8. The unit will display "ON SETPOINT".
9. Press **ENTER**. The unit will display 0.0.
10. Press the **UP** or **DOWN** keys to scroll to the ON SETPOINT you have defined on your worksheet.
11. Press **ENTER**. SAVING will appear briefly on the display and the display will shift to OFF SETPOINT.
12. Press **ENTER**. The unit will display 0.0.
13. Press the **UP** or **DOWN** keys to scroll to the Off Setpoint you have defined on your worksheet.
14. Press **ENTER**. SAVING will appear briefly on the display and the display will shift to ON SETPOINT.

Analog Output

The optional analog output module gives the LevelCom 100 a 4 – 20 mA output capability. The output can function either as a gauge output to remotely indicate depth,

volume, or weight to a remote meter, or data acquisition system. If the LevelCom 100 has the auto specific gravity option installed the analog output can also function as a specific gravity gauge output.

It is also possible to configure the analog output as a control output. In this case there are 4 adjustable parameters to configure the output value. The Minimum Current is a value between 4 mA and 20 mA. The maximum current is a value between the minimum current value and 20 mA. The Minimum Current Setpoint is the depth where the output signal takes the minimum value. The Maximum Current Setpoint is the depth where the output signal takes the maximum value. This gives great flexibility in the configuration of the analog output.

If the Minimum Current Setpoint is below the Maximum Current Setpoint, the current will be at the Minimum Current value when the level is below the Minimum Current Setpoint. The output will vary smoothly from the Minimum Current value to the Maximum current value when the level is between the setpoints. When the level is above the Maximum Current Setpoint, the output current will remain at the Maximum Current value.

If the Minimum Current Setpoint is above the Maximum Current Setpoint, the current will be at the Maximum Current value when the level is below the Maximum Current Setpoint. The output will vary smoothly from the Maximum Current value to the Minimum current value when the level is between the setpoints. When the level is above the Minimum Current Setpoint, the output current will remain at the Minimum Current value.

Configure as a Gauge Output

1. Enter Program Mode by pressing the **MENU** key.
2. At SYSTEM press the **UP** or **DOWN** keys to scroll to OUTPUTS.
3. Press **ENTER**. The unit will display LIGHTS.
4. Press the **DOWN** key until unit displays ANALOG OUTPUT.
5. Press **ENTER**. The unit will display GAUGE.
6. Press **MENU** to select this function. An asterisk (*) will appear to the right of the display indicating the function has been selected.
7. Press **ENTER**. SAVING will appear briefly on the display. The unit will display DEPTH.
8. Press the **UP** or **DOWN** keys to scroll through the menu selections.
9. Press **MENU** key to select the gauge output you want.
10. Press **ENTER**. SAVING will appear briefly on the display and the display will shift to GAUGE.
11. Press **ESCAPE** to return to normal operation.

Specific Gravity Gauge Output Setup

If the analog output is configured as a specific gravity gauge output there is an additional consideration. The span of the 4 – 20 mA signal must be set up. This requires setting the minimum specific gravity

value, which corresponds to the 4 mA, and setting the maximum specific gravity value, which corresponds to the 20 mA signal.

1. Enter Program Mode by pressing the **MENU** key.
2. At SYSTEM press the **UP** or **DOWN** keys to scroll to OUTPUTS.
3. Press **ENTER**. The unit will display LIGHTS.
4. Press the **DOWN** key until unit displays ANALOG OUTPUT.
5. Press **ENTER**. The unit will display GAUGE.
6. Press **MENU** to select this function. An asterisk (*) will appear to the right of the display indicating the function has been selected.
7. Press **ENTER**. SAVING will appear briefly on the display. The unit will display DEPTH.
8. Press the **UP** or **DOWN** keys to scroll through the menu selections until the display shows SPECIFIC GRAVITY.
9. Press **MENU** key to select this option.
10. Press **ENTER**. SAVING will appear briefly on the display and the display will shift to MIN S G.
11. Press **ENTER**. The unit will display 0.0.
12. Press the **UP** or **DOWN** keys to scroll to the MIN SG value you have defined on your worksheet.

13. Press **ENTER**. SAVING will appear briefly on the display and the display will shift to MIN SG.
14. Press the **UP** or **DOWN** keys to scroll to MAX SG.
15. Press **ENTER**. The unit will display 0.0.
16. Press the **UP** or **DOWN** keys to scroll to the MAX SG value you have defined on your worksheet.
17. Press **ENTER**. SAVING will appear briefly on the display and the display will shift to MAX SG.
18. Press **ESCAPE** to return to normal operation.

Configure as a Control Output

1. Enter Program Mode by pressing the **MENU** key.
2. At SYSTEM press the **UP** or **DOWN** keys to scroll to OUTPUTS.
3. Press **ENTER**. The unit will display LIGHTS.
4. Press the **DOWN** key until unit displays ANALOG OUTPUT.
5. Press **ENTER**. The unit will display GAUGE.
6. Press **DOWN** key until unit displays CONTROL.
7. Press **MENU** to select this function. An asterisk (*) will appear to the right of the display indicating the function has been selected.

8. Press **ENTER**. SAVING will appear briefly on the display. The unit will display MIN SETPOINT.
9. Press **ENTER**. The unit will display 0.0.
10. Press the **UP** or **DOWN** keys to scroll to the MIN SETPOINT value you have defined on your worksheet.
11. Press **ENTER**. SAVING will appear briefly on the display and the display will shift to MIN SETPOINT.
12. Press **DOWN** until the machine displays MIN CURRENT.
13. Press **ENTER**. The unit will display 0.0.
14. Press the **UP** or **DOWN** keys to scroll to the Minimum Current you have defined on your worksheet.
15. Press **ENTER**. SAVING will appear briefly on the display and the display will shift to MIN CURRENT.
16. Press **DOWN** until the machine displays MAX SETPOINT
17. Press **ENTER**. The unit will display 0.0.
18. Press the **UP** or **DOWN** keys to scroll to the MAX SETPOINT value you have defined on your worksheet.
19. Press **ENTER**. SAVING will appear briefly on the display and the display will shift to MAX SETPOINT.
20. Press **DOWN** until the machine displays MAX CURRENT
21. Press **ENTER**. The unit will display 0.0.

22. Press the **UP** or **DOWN** keys to scroll to the MAX CURRENT value you have defined on your worksheet.
23. Press **ENTER**. SAVING will appear briefly on the display and the display will shift to MAX CURRENT.
24. Press **ESCAPE** to return to normal operation.

Manual Analog Output

The analog output can be operated in manual mode when it is set up as a control output. This mode can be used to test the system, and any devices that receive the signal from the LevelCom 100. This may be used to test the system if the output is to be used as a gauge output as well. The machine must be temporarily set up as a control output to use this function though, and you must be sure to switch the configuration back to a gauge output when you are done testing.

1. Enter Program Mode.
2. At SYSTEM press the **UP** or **DOWN** keys to scroll to OUTPUTS.
3. Press **ENTER**. The unit will display LIGHTS.
4. Press the **DOWN** key until unit displays ANALOG OUTPUT.
5. Press **ENTER**. The unit will display GAUGE.
6. Press **DOWN** key until unit displays CONTROL.
7. Press **MENU** to select this function if it isn't already selected. An asterisk (*)

will appear to the right of the display indicating the function has been selected.

8. Press **ENTER**. SAVING will appear briefly on the display. The unit will display MIN SETPOINT.
9. Press the **UP** or **DOWN** keys to scroll to the MANUAL.
10. Press **MENU** to select the manual mode. An asterisk (*) will appear to the right of the display indicating the function has been selected.
11. Press **ENTER**. The unit will display 0.0%. The display shows percent of output signal now, 0% is 4 mA and 100% is 20 mA.
12. Press the **UP** or **DOWN** keys to scroll to the output signal level you want.

The machine may be returned to normal operation now if you want to leave a manual output value on the machine. In this case press **ESCAPE** to return to normal operation. The machine will flash the word MANUAL on the display every few seconds to indicate that it is in manual analog output mode.

If you want to return to a controlled analog output follow the instructions from here.

13. Press **ESCAPE**. The display will shift to MANUAL. There will be an asterisk (*) indicating that the machine is in Manual mode.
14. Press **MENU** to clear the asterisk.
15. Press **ENTER**. SAVING will appear briefly on the display and the display will say MANUAL with no asterisk. The

machine will now automatically run the analog output.

16. Press **ESCAPE** to return to normal operation.

Note: If the machine is to run as a gauge output make sure to switch it back to GAUGE before leaving this menu.

Digital Communication Interface

This optional output is an interface for communication with up to four LevelCom 101 Repeater devices. These devices provide a full remote readout for a LevelCom 100. This communication interface is separate from the RS-422/485 interface, and does not affect the function of that device. For that setup see page 31.

This example will assume that there are two LevelCom 101 Repeaters set up with addresses 50 and 51 respectively.

Note: The Network Address programmed into the LevelCom 100 can not be the same as either of these two Repeater ID numbers. Make sure of this before you complete this configuration. The Network Address is found under the UTILITIES menu.

1. Enter Program Mode by pressing the **MENU** key.
2. At SYSTEM press the **UP** or **DOWN** keys to scroll to OUTPUTS.
3. Press **ENTER**. The unit will display LIGHTS.
4. Press the **DOWN** key until unit displays DIGITAL COMMUNICATION.
5. Press **ENTER**. The unit will display ID1.

6. Press **ENTER**. The unit will display 49.
7. Press the **UP** or **DOWN** keys to scroll to the ID number of the first Repeater, 50 in this case.
8. Press **ENTER**. SAVING will appear briefly on the display and the display will shift to ID 1.
9. Press **DOWN** until the machine displays ID 2.
10. Press **ENTER**. The unit will display 49.
11. Press the **UP** or **DOWN** keys to scroll to the ID number of the first Repeater, 51 in this case.
12. Press **ENTER**. SAVING will appear briefly on the display and the display will shift to ID 2.

Note: It is necessary to check the remaining ID numbers and set them to 255. If the unused ID numbers are not set to 255 the performance of the communication interface is severely reduced, as the machine attempts to communicate with devices that are not present. Setting an ID number to 255 disables communication to that channel.

13. Press **DOWN** until the machine displays ID 3.
14. Press **ENTER**. The unit will display 49.
15. Press the **UP** or **DOWN** keys to scroll to 255.
16. Press **ENTER**. SAVING will appear briefly on the display and the display will shift to ID 3.

17. Press **DOWN** until the machine displays ID 4.

18. Press **ENTER**. The unit will display 49.

19. Press the **UP** or **DOWN** keys to scroll to 255.

20. Press **ENTER**. **SAVING** will appear briefly on the display and the display will shift to ID 4.

21. Press **ESCAPE** to return to normal operation.

Programming Worksheet Explained

This section provides a description of the Programming Worksheet. This worksheet allows the user to analyze the parameters associated with a given tank and to collect the data in a format that follows the programming procedure. The worksheet below contains explanations of the functions of the data, and guidance in the program setup. **Do not fill in this worksheet; it is for explanation purposes only.**

On page 53 you will find a two page Programming Worksheet. Make enough copies of the Programming Worksheet so you will have one full copy for each LevelCom 100. Your worksheets serve as the record of your LevelCom 100 installations and should be kept on file.

In a pocket inside the back cover you will find the Configuration Flow Chart. This is a “tree” chart that documents the program flow path. Referencing this chart will help you to understand the operation and flexibility of the LevelCom 100.

Programming Worksheet

Tank: _____ Service: _____ Address: _____
Password: _____

Display Setup

This section establishes the display functions of the LevelCom 100. Select the depth, volume and weight units desired. If ullage is to be displayed in any of the units selected then also check ullage. Display Units determines the units that will be displayed by the LevelCom 100. In operation, pressing the **ESCAPE** key will scroll the LevelCom 100 display to the next display parameter.

For example, let's say you have selected Feet & Inches, Barrels and Long Tons as units of measure and have selected Volume Units for display. By pressing the **ESCAPE** key, the instrument will momentarily display L TONS and then indicate the tonnage on the digital display. Pressing ESC again will bring up FEET INCHES followed by the depth. This will remain on the display for approximately 20 seconds and will automatically return to the normal volume display in Barrels.

If the tank service is changed, i.e. fuel oil/ballast, simply select the new Display Unit and modify the Specific Gravity as necessary. The LevelCom 100 will automatically convert the parameters.

(Select one in each category. Select Ullage if desired)

Depth Units: Inches___ Feet___ Feet and Inches___ Centimeters___ Meters___ Ullage___

Volume Units: Not Used___ Gallons___ K Gallons___ Liters___ K Liter___ Ullage___

Weight Units: Not Used___ Short Tons___ Long Tons___ Metric Tons___ Ullage___

Display Units: Depth___ Volume___ Weight___

Specific Gravity

For programming purposes, it is important to use the specific gravity value that was used to establish the sounding or tank data from which the Tank Table data was derived. The specific gravity can be adjusted to the present (or future) contents of the tank after programming is complete. With each update of specific gravity, the LevelCom 100 will recalculate the Tank Table level and weight data and correct the display accordingly.

Specific Gravity: _____

Tank Table

This programming section defines the physical properties of the tank. Use caution when gathering the data for the Tank Table. Remember that the LevelCom 100 (and any other pressure based level indicator) measures the **vertical** pressure of a liquid column. Because of angularity of sounding tubes and the location of the sounding port, sounding tables are often **not** true vertical representations of the tank's depth to volume characteristics. On some ships, we have seen instances where the sounding tables indicate depths greater than the actual depth of the vessel itself. The Tank Capacity Curves, ullage tables or other engineering data are sources for the vertical data required. As a last resort, the data may be found on the scales of the old tank level indicators; however, in most instances the LevelCom 100 is much more accurate than "eyeballing" the scales.

If the depth is the only parameter to be displayed, then you need only program Maximum Depth and Bubbler to Bottom. However, if the tank is non-linear (the cross section changes with depth) and volume and/or weight is to be displayed, then the Tank Table must be programmed.

The multiple levels (Max Depth and D9-D1) in the Tank Table are used to define the depth to volume/weight curve for non-linear tanks. To maximize accuracy of the instrument we recommend a graph of the depth to volume curve be created using Excel, Lotus, etc. **Beginning at the top of the tank and working downward**, set Tank Table points along the graphed curve. The LevelCom 100 will interpolate a straight line between the points. Use as many points (D9-D1) as are needed to follow the curve as close as possible. Points must be entered from the top (D9) down. Leave unused points blank.

If the LevelCom 100 is being programmed for a tank used for multiple purposes (e.g. fuel oil/ballast) and the instrument will be displaying volume and weight depending on contents (e.g. fuel oil - Barrels, ballast - Long Tons) it is only necessary to enter **either** volume or weight. The LevelCom 100 will automatically convert the Tank Table to track the other parameter when the instrument is reconfigured. To ensure maximum accuracy, we recommend using volume data, if available, for programming the Tank Table.

Max Depth: _____	(In Depth Units of measure selected above)	
Max Volume: _____	(In Volume Units selected above)	
OR		
Max Weight: _____	(In Weight Units selected above)	
D9: _____	V9: _____	W9: _____
D8: _____	V8: _____	W8: _____
D7: _____	V7: _____	W7: _____
D6: _____	V6: _____	W6: _____
D5: _____	V5: _____	W5: _____
D4: _____	V4: _____	W4: _____
D3: _____	V3: _____	W3: _____
D2: _____	V2: _____	W2: _____
D1: _____	V1: _____	W1: _____
Bubbler to Bottom _____	(In Depth Units)	

Bubbler to Bottom is the distance between the end of the sense line and the bottom of the tank.

Distance between Bubbler and Specific Gravity sense lines _____	(In Depth Units)
--	------------------

This parameter is only used if the Automatic Specific Gravity option has been installed. It defines the **vertical** distance between the lower and upper (Specific Gravity) sense lines. When the liquid level is higher than the upper sense line, the LevelCom 100 calculates the pressure differential and adjusts the specific gravity accordingly.

Timing

This section establishes the frequency of the sample and purge cycles as well as the purge duration. In the Sample Timing part of the program, enabling Auto in addition to another Sample Rate will cause the LevelCom 100 to automatically update the display whenever a change in level is detected. If Auto is not enabled, the instrument will not update the display until the next sample time, however the display will flash indicating that the level has changed. This is done for those instances where sensing air is limited or levels may be changing due to vessel rolling. Selecting Fast will cause the LevelCom 100 to continuously and rapidly update the display. This mode should only be used in conditions requiring close monitoring of tank evolutions (e.g. monitoring of overfill standpipe during bunkering operations).

Sample Timing: Auto___ Fast___ 10 Sec___ 15 Sec___ 30 Sec___ 1 Min___ 5 Min___ 10 Min___
 15 Min___ 30 Min___ 1 Hr___ Demand___
Purge Frequency: 1 Hr___ 2 Hrs___ 6 Hrs___ 12 Hrs___ 1 Day___ 2 Days___ 4 Days___ 7 Days___
 Demand___
Purge Duration: 5 through 30 Seconds_____

Outputs

Lights refers to the LevelCom 100 front panel alarm lights. If selected, the High Alarm LED will activate on Hi-Hi and Hi alarms. Similarly the Low Alarm LED will activate on Lo Lo and Lo alarms. Horn is an optional front panel mounted piezoelectric alarm horn that will activate on the selected alarm points.

If Latch is selected, the lights and/or horn will remain activated until the operator presses the **ACK** button. If Latch is not selected, the lights and/or horn will automatically clear once the alarm condition has passed. The optional relays (1&2) can be configured to activate remote high or low alarms, to perform control functions or to indicate a failure in the LevelCom 100 or in the sense line.

Lights: Hi Hi___ Hi___ Lo___ Lo Lo___ Latch___
Horn (optional): Hi Hi___ Hi___ Lo___ Lo Lo___ Latch___
Relay 1 (optional): (Select one) Alarm___ Control___ System Failure___
Relay 1 Alarm: (In Display Units) Hi Hi___ Hi___ Lo___ Lo Lo___
Relay 1 Control: (In Display Units) On Setpoint___ Off Setpoint___
Relay 2 (optional): (Select one) Alarm___ Control___ System Failure___
Relay 2 Alarm: (In Display Units) Hi Hi___ Hi___ Lo___ Lo Lo___
Relay 2 Control: (In Display Units) On Setpoint___ Off Setpoint___

Alarm Setpoints (In Display Units)

Using the selected Display Units, establish the alarm setpoints and hysteresis. Hysteresis is the distance the level must travel to automatically clear the alarm. For example, if the Level-Com 100 is set up to display depth, and the Hi-Hi setpoint is 10' 0.0". With a 6.0" hysteresis, the Hi-Hi alarm will activate on a climbing level at 10'. When the level drops, the alarm will clear at 9' 6.0".

Hi-Hi: Setpoint___ Hysteresis___
Hi: Setpoint___ Hysteresis___

Hi and Hi-Hi alarms are adjustable between Bubbler to Bottom and 110% Max Depth. This is to allow the user to configure the program to tanks that are often “pressed” or purposely overflowed (e.g. vessel double-bottom fuel tanks).

Lo: Setpoint_____ Hysteresis_____
Lo Lo: Setpoint_____ Hysteresis_____

Lo alarms are adjustable between Bubbler to Bottom and Max Depth

Hot Menu

The LevelCom 100 is programmed with a “Hot Menu” which allows the user to access and change certain program features and parameters without the need to enter into the complete program. Use discretion in setting up the “Hot Menu”, as these selections will not be password protected

Sample Timing ____	Specific Gravity (Manual)____	Purge Now ____	Display Units ____
Display Mode ____	Relay 1 Control Setpoints ____	Relay 2 Control Setpoints ____	
Alarm Setpoints ____			

Programming Worksheet

Tank: _____ Service: _____ Address: _____
Password: _____

Display Setup

Depth Units: Inches___ Feet___ Feet and Inches___ Centimeters___
Meters___ Ullage___

Volume Units: Not Used___ Gallons___ K Gallons___ Liters___ K Liters___
Cubic Feet___ Barrels___ Ullage___

Weight Units: Not Used___ Short Tons___ Long Tons___ Metric Tons___
Ullage___

Display Units: Depth___ Volume___ Weight___

Specific Gravity

Specific Gravity: _____

Tank Table

Max Depth: _____ (In Depth Units of measure selected above)

Max Volume: _____ (In Volume Units selected above)

OR

Max Weight: _____ (In Weight Units selected above)

D9: _____	V9: _____	W9: _____
D8: _____	V8: _____	W8: _____
D7: _____	V7: _____	W7: _____
D6: _____	V6: _____	W6: _____
D5: _____	V5: _____	W5: _____
D4: _____	V4: _____	W4: _____
D3: _____	V3: _____	W3: _____
D2: _____	V2: _____	W2: _____
D1: _____	V1: _____	W1: _____

Bubbler to Bottom: _____ (In Depth Units)

Distance between Bubbler and Specific Gravity sense lines _____ (In Depth Units)

Timing

Sample Timing: Auto___ Fast___ 10 Sec___ 15 Sec___ 30 Sec___ 1 Min___

5 Min___ 10 Min___ 15 Min___ 30 Min___ 1 Hr___ Demand___

Purge Frequency: 1 Hr___ 2 Hrs___ 6 Hrs___ 12 Hrs___ 1 Day___ 2 Days___

4 Days___ 7 Days___ Demand___

Purge Duration: 5 through 30 Seconds___

Outputs

Lights: Hi-Hi_____ Hi_____ Lo_____ Lo Lo_____ Latch_____

Horn (optional): Hi Hi_____ Hi_____ Lo_____ Lo Lo_____ Latch_____

Relay 1 (optional): (Select one) Alarm_____ Control_____ System Failure_____

Relay 1 Alarm: Hi Hi_____ Hi_____ Lo_____ Lo Lo_____

Relay 1 Control: (In Display Units) On Setpoint_____ Off Setpoint_____

Relay 2 (optional): (Select one) Alarm_____ Control_____ System Failure_____

Relay 2 Alarm: Hi Hi_____ Hi_____ Lo_____ Lo Lo_____

Relay 2 Control: (In Display Units) On Setpoint_____ Off Setpoint_____

Alarm Setpoints (In Display Units)

Hi Hi: Setpoint_____ Hysteresis_____

Hi: Setpoint_____ Hysteresis_____

Lo: Setpoint_____ Hysteresis_____

Lo Lo: Setpoint_____ Hysteresis_____

Hot Menu

Sample Timing____ Specific Gravity (Manual)____ Purge Now____ Display Units____

Display Mode____ Relay 1 Control Setpoints____ Relay 2 Control Setpoints____

Alarm Setpoints____

Calibration

Pneumatic Sensor Calibration

The LevelCom 100 performs a Hardware Zero when the power is applied and approximately every hour thereafter. Calibration is not a routine maintenance procedure. If you are not sure whether to proceed with calibration please contact TMS for guidance prior to adjusting the instrument. **This procedure must be performed by a qualified technician.**

Required Equipment

- Calibration gauge accurate to at least 0.1" H₂O (The gauge must have an adequate range for the sensor in the LevelCom 100).
- Hand pump.
- Fittings (1/8" NPT) and tubing to hook up to the LevelCom 100.

Field Calibration Procedure

Note: This procedure assumes familiarity with the LevelCom 100 program. If you require assistance in entering the program please refer to the programming sections of the manual and the Configuration Flow Chart. The CALIBRATE menu is an item in the UTILITIES menu.

1. Determine the type of pressure sensor installed in the LevelCom 100 by inspecting the white silk-screened area of the Pressure Sensor Circuit Board (Refer to Figure 12 for the location).
2. Connect a fitting to **PORT 1 DRAIN** on the LevelCom 100 if there is not al-

ready a fitting in place (Refer to Figure 11 for the location).

3. Enter the LevelCom 100 configuration interface. Access the CALIBRATE

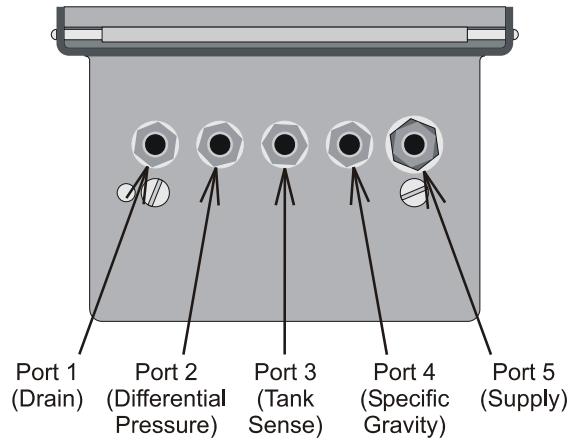

Figure 11 Bottom View of LevelCom 100

menu and select "FIELD CAL". Press **ENTER**. The output from the pressure sensor will be displayed. This is a number directly from the hardware. It is not scaled into any engineering units.

4. For 15 PSI and 30 PSI sensors the number should be near 50, for 100 PSI sensors the number should be near 80. If this is the case, press **ACK** and proceed to step 5.
5. Adjust the **OFFSET** potentiometer on the pressure sensor circuit board until the display reads 50 if the for a 15 PSI or 30 PSI sensor, or 80 for a 100 PSI sensor (Refer to Figure 12 for the location of the OFFSET potentiometer). Press **ACK** when this step is done and proceed to step 5.

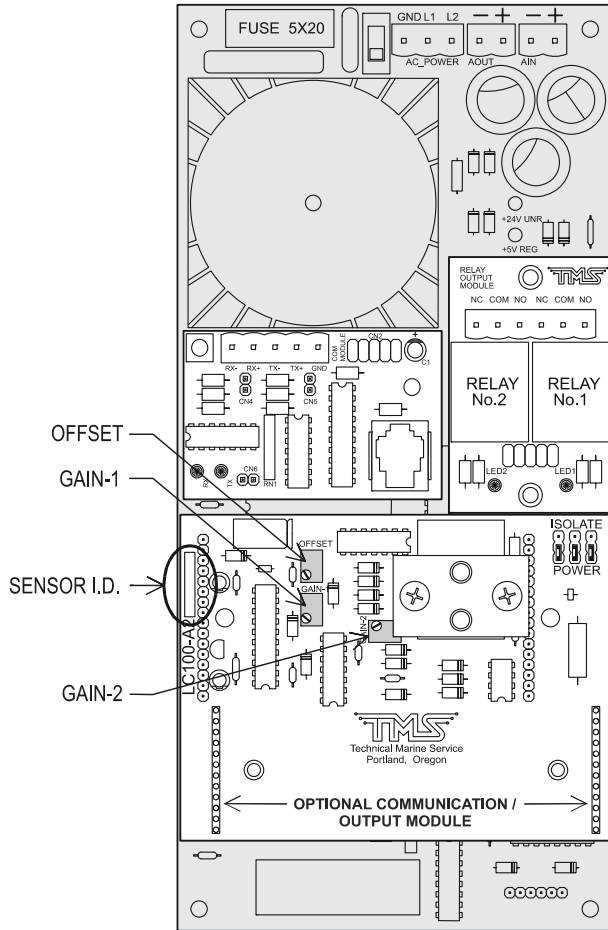

Figure 12 LevelCom 100 Interior

6. Using the appropriate tubing and fittings, connect the calibration gauge and the hand pump to the two opposing sides of a "T" fitting. Connect the center of the "T" fitting to the **PORT 1 DRAIN** on the LevelCom 100.
7. Using the hand pump and calibration gauge apply the following pressure to the LevelCom 100 based on the pressure sensor type installed:

15 PSI	400.0" H ₂ O	(14.45 psi)
30 PSI	800.0" H ₂ O	(28.90 psi)
100 PSI	1200.0" H ₂ O	(43.35 psi)
100 PSI 16 bit	2400.0" H ₂ O	(86.70 psi)

The instrument will now read the applied pressure in inches of water to an accuracy of 0.1". If the reading is different from this value adjust the **GAIN-1** potentiometer until the correct reading shows on the display, agreeing with the reading on the calibration gauge. (Refer to Figure 12 for the location of the GAIN-1 potentiometer)

Note: It is very important here that the hand pump and calibration gauge setup does not leak. It is very difficult to do this adjustment correctly if there are even small leaks in the calibration equipment.

8. Disconnect the calibration gauge / hand pump assembly from the **PORT 1 DRAIN** fitting and press **ACK** to re-check the zero offset value. If the zero offset value is different than it was when measured before, repeat steps 3 through 6 until both measurements are correct.

9. Select "CHAN-1" from the Calibrate menu. Re-connect the calibration gauge / hand pump assembly to the **PORT 1 DRAIN** on the LevelCom 100.

10. Using the hand pump and calibration gauge apply the following pressure to the LevelCom 100 based on the pressure sensor type installed:

15 PSI	400.0" H ₂ O	(14.45 psi)
30 PSI	800.0" H ₂ O	(28.90 psi)
100 PSI	1200.0" H ₂ O	(43.35 psi)
100 PSI 16 bit	2400.0" H ₂ O	(86.70 psi)

11. The LevelCom 100 display should show a number near 3200. Adjust the **GAIN-2** potentiometer until the correct reading of 3200 is on the display. (Refer to Figure 12 for the location of the GAIN-2 potentiometer)

12. The calibration is complete. Remove any fittings that were attached for calibration, and return the LevelCom 100 to normal operation. Verify that it is reading the correct depth for the liquid in the tank.

Note: Remember that the LevelCom 100 reads out differently in different parts of the above procedure. When you are setting the zero level the LevelCom 100 is reading out unscaled numbers from the Analog to Digital converter on the sensor board. At this point there will be no decimal point shown. When you are setting the span value the LevelCom 100 will display pressure in inches of water. Since the LevelCom 100 displays with a resolution of 0.1 inches you will see a decimal point on the display. The **ACK** button toggles between these two states. It is very important that there is no pressure on the system when you toggle to the state for setting the span. The zero reading you set is read and used to process the span reading and the zero is recorded when the **ACK** button is pressed.

The readings on the display are filtered to reduce noise for readability. To reduce waiting time press the **MODE** button to bypass the filter algorithm. When the **MODE** button is released the filter functions as usual.

Analog Output Calibration

The calibration of the 4-20 mA analog output can be checked and adjusted with the following procedure. Calibration is not a routine maintenance procedure. If you are not sure whether to proceed with calibration please contact TMS for guidance prior to adjusting the instrument. **This procedure must be performed by a qualified technician.**

Required Equipment

1. Accurate current meter for reading the current output value.
2. Wire leads to connect to the LevelCom 100 analog output connector.

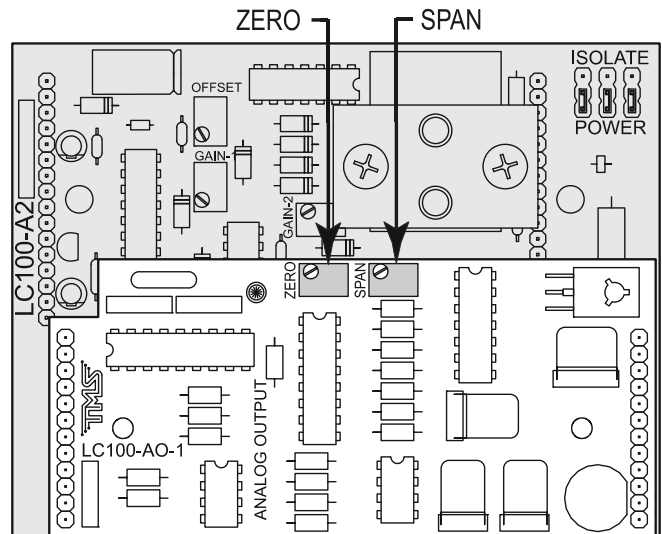

Figure 13 LC100-AO-1 Calibration Potentiometers

Note: If the analog output is being used as a control output be sure to secure the controlled process before you begin because you may be disconnecting the LevelCom 100 from the controlled process, or you may be generating meaningless control signals while performing the calibration procedure.

Calibration Procedure

1. Connect the meter to the Analog output connector. If the LevelCom 100 is set up to power the analog output you can connect directly to the terminals, however if the output is set up to be externally powered you will need to connect the meter into the complete circuit.

2. Enter the LevelCom 100 program. Access the Calibrate menu and select "AN OUT". Press **ENTER**. "ZERO" will be displayed. Press **ENTER**. The meter should read 4 mA. If it doesn't, adjust the **ZERO** potentiometer on the analog output board until the meter reads 4 mA. (Refer to Figure 13 for the location of the ZERO potentiometer)
3. Press the **UP** or **DOWN** keys to scroll to "SPAN" and press **ENTER**. The meter should read 20mA. If it doesn't, adjust the **SPAN** potentiometer until the meter reads 20 mA. (Refer to Figure 13 for the location of the SPAN potentiometer)
4. Press the **UP** or **DOWN** keys to scroll to "ZERO" and press **ENTER**.
5. The meter should read 4 mA. If it does the calibration is complete, if not repeat steps 2 – 4 until the meter reads 4 mA when you enter ZERO, and 20 mA when you enter SPAN.
6. Now you can check the linearity of the output with the other items in this menu. When the span and zero calibration is done entering the following menu items should give the following meter readings:
 - 25% - 8 mA
 - 50% - 12 mA
 - 75% - 16 mA

This completes the test and calibration of the analog output circuit.

Troubleshooting

The LevelCom 100 is programmed to monitor certain system functions and to display error messages when abnormal situations are detected. These functions include:

Supply Air Pressure - High or low pressure.

Sense Line - Plugged or leaking Sense line.

Internal functions - Sensor zero and EEPROM functions.

The following details some of the problems, which may be encountered and corrective actions to be taken.

Note: The LevelCom 100 is a delicate electronic instrument. Qualified individuals must perform repairs and troubleshooting.

Instrument displays CAN'T ZERO SENSOR.

The LevelCom 100 does a power on self-test when it is powered up. Among other things, the zero offset of the sensor circuit is read and stored in memory. The zero offset is expected to have a value near a pre-calibrated value. This zero offset measurement is also performed approximately once every half hour of operation. If the measured zero offset is outside a specific range, this error message is displayed. There are a few different causes of this condition.

Probably the most common cause is water condensed in the supply air system. The LevelCom 100 runs a purge sequence pe-

riodically to clear the sense line and remove accumulated water from its internal pneumatic system. However if the machine does not purge often enough (the purge timing is programmable) water may accumulate faster than it is removed from the system. This case can easily be verified by disconnecting the supply air tubing to see if there is water present in the supply air. Drain any water from the air supply lines and regulator, and reconnect the LevelCom 100. When the LevelCom 100 is powered up, the condition should not appear.

It is also possible that the drain valve is not functioning. It may be partially or completely blocked with foreign material, or the electrical system may not be operating the valve at all. To test the valves enter the CALIBRATE menu (See the Configuration Flow Chart) and select VALVES. The front panel buttons will now directly operate the valves as listed below:

<u>BUTTON</u>	<u>VALVE</u>
ENTER	Supply
DOWN	Specific Gravity
MENU	Tank Sense
UP	Differential Pressure
ACK	Drain

All valves will be de-energized when this test mode is entered. With the LevelCom 100 connected to its air supply press **ENTER** to open the Supply valve. The drain valve is open when de-energized so air should blow out of the Drain when the Supply valve is opened in this test. If this doesn't happen, first verify that the proper air supply pressure is present. If there is too high a supply pressure present the

Supply valve may not open (it will be held closed by the air pressure). Check that the LED on the small valve interconnect circuit board lights when the button is pressed (try the other buttons to see if any LEDs light). If the supply valve is working, the drain valve may be plugged. Inspect the clear tubing running from the top of the Drain valve to the aluminum manifold to see if there has been any contamination present. If the valve is plugged it will have to be replaced.

Inspect the clear tubing running from the manifold to the sensor. If there is any contamination in this tubing it may be the problem. Any liquid that has accumulated in the tubing must be removed.

It is also possible that the supply valve is leaking. This is easy to detect in the valve test mode. If the supply valve is leaking there will be a steady flow of air out of the de-energized drain valve.

If everything checks out at this point and the error condition still appears then the sensor circuit may need calibration. It is possible that the sensor has failed. The calibration procedure will detect this. See the calibration procedure in this manual. Calibration should be done only after all other possibilities have been exhausted.

Instrument displays EEPROM FAILURE.

This message indicates trouble with the EEPROM (Electrically Erasable Programmable Read Only Memory) memory that is used to hold the LevelCom 100 configuration. If this message occurs when the LevelCom 100 is powered up it means that there were problems reading the configuration from the EEPROM. If this message occurs when changing the LevelCom 100 configuration it means that there were

problems detected while writing new information to the EEPROM. In this case the new information was not completely stored, but the old information was probably at least partially modified. The message could mean that there has been a true electrical failure of the EEPROM, however this is not the only possibility. The following will describe some tests to determine the cause of the problem.

Turn the LevelCom 100 off and after a short time restore power. If the message does not appear this time it may indicate that the problem was caused by electrical noise getting into the LevelCom 100 system. This could happen if there are relays installed and the relays are driving a large inductive load, like a motor or a solenoid (please note that the relays are rated "Pilot Duty Only"). If the relay is driving a DC relay or solenoid there should be a free-wheeling diode in the circuit or else large voltage spikes will be generated on the control circuit when the relay contacts open. These spikes can generate powerful radio frequency pulses that can effect nearby electronic devices. Similarly if the relay is operating an AC motor, either directly, or through a slave relay both the starting and stopping of the motor can generate voltage spikes on the power lines and these spikes can possibly affect the LevelCom 100 electronics. In this case putting capacitors across the motor terminals can sometimes help.

This problem will not always show up immediately in a new installation. The LevelCom 100 always verifies the updated contents of the EEPROM as it writes new information. If this verification fails, the LevelCom 100 tries again and signals a failure only after a number of verification failures. The LevelCom 100 stores multiple copies of the configuration and there is

unused space in the EEPROM of a new LevelCom 100 that can be used for configuration information if there is a partial failure of the EEPROM. The electrical noise described above can interfere with EEPROM operations in extreme cases. In this case there will not actually be a failure of the EEPROM but because of the electrical noise, there may have been verification failures causing the LevelCom 100 to use new areas of the EEPROM. When all available space is used up the LevelCom 100 will generate the EEPROM FAILURE message. As a result the machine will work well for awhile and then start showing the EEPROM FAILURE condition. A way to check for this is to select the ERASE ALL MEMORY option in the MEMORY menu. This will completely erase any configuration information in the EEPROM and the LevelCom 100 will need to be reconfigured before being put back into operation. Then if the machine works well for awhile and once again starts showing the EEPROM FAILURE condition electrical noise is probably causing the trouble.

If erasing the EEPROM does not get rid of the condition then there is probably something wrong with the EEPROM and it will need to be replaced.

Instrument displays CHECK AIR.

This message will be displayed if there is either insufficient or excessive air pressure for proper machine operation. Check the regulator to make sure that the machine is getting supply air. If supply air is present make sure that the pressure is not too high. If the input air pressure is too high the supply valve will not be able to open. If there is a gauge on the regulator, make sure that this gauge is reading correctly. Finally make sure that there is not water in the supply air lines or that the regulator

bowl is not full of water. Loosen the supply air fitting at the LevelCom 100 to make sure that air can flow to the LevelCom 100.

If all these things check out there may be a problem with the Supply valve. Use the VALVES utility in the calibrate menu. Operate the Supply valve manually and air should come out of the Drain port. If nothing happens make sure that the LED on the valve board lights when the **ENTER** button is pressed to operate the valve. If the LED doesn't light make sure that the flat cable is properly plugged onto the connector on the valve board. If the connector is attached and the LED still doesn't light and the valve does not operate then there is probably an electrical problem on the main controller board. If the LED lights but the valve does not operate the Supply valve has probably failed.

The CALIBRATE menu.

This menu provides utilities for testing and calibrating the LevelCom 100. It is found in the UTILITIES menu. Below are descriptions of the items in this menu.

The **CHAN-0** item gives direct access to the main output from the sensor circuit. When this item is activated the display shows the output of the analog to digital converter. This output is also useful to verify that the sensor circuit is functioning. When this item is activated the valves are all de-energized. The Drain valve is run as a normally open valve so the Drain port now gives access to the pressure sensor input. It is easy to verify that the sensor circuit is working by applying a little air pressure to the Drain port and verifying that the numbers on the display increase with increasing pressure. The ESCAPE key is used to exit this utility.

The **CHAN-1** item works exactly like the CHAN-0 item. It gives access to a secondary signal from the sensor circuit that is used primarily for control of the Supply valve. The ESCAPE key is used to exit this utility.

The **VALVES** item gives direct access to the solenoid valves. When activated the front panel buttons are used to activate the valves.

The following list shows which buttons run which valves.

<u>BUTTON</u>	<u>VALVE</u>
ENTER	Supply
DOWN	S.G.
MENU	Tank Sense
UP	D.P.
ACK	Drain

The ESC key is used to exit this utility. This item is useful for testing the valves. This utility must be used with some caution however. In normal operation the LevelCom 100 is continually checking the pressure and the Supply valve will be closed if the pressure is too high. This is done to protect the sensor. When this utility is used the operator must verify that the sensor does not get exposed to too high a pressure. This is NOT a way to clear a plugged sense line for example, the sensor could be permanently damaged this way. It is also possible, depending on the sense line installation, that liquid from the tank could siphon back to the LevelCom 100 if the Tank Sense valve is held open for an extended period. This could result in damaging contamination to the LevelCom 100 and some danger to the operator depending on the liquid in the tank. **It is the responsibility of the operator to use this utility in a safe manner.**

The **RELAYS** item gives direct access to the relays. When activated the UP button operates Relay 1, the DOWN button operates Relay 2. The relays de-energize on entering this utility. Pressing the appropriate button energizes the associated relay. This is useful for testing the function of the relays and the condition of the relay contacts. It is a useful utility when wiring to external alarm systems or control devices. The ESCAPE key is used to exit this utility.

The **HORN** item is used to test the installed Sonalert device in the LevelCom 100. It is useful only if the horn option is installed. The ESCAPE key is used to exit this utility.

The **DISPLAY** item is used to test the entire display. When activated the character display will show a rotating pattern that lights all segments in a digit including the decimal point. The UP key will cause the bar graph to light starting from the bottom to the top. The DOWN key will cause the bar graph lights to go out starting from the topmost lit segment down to the bottom. The alarm setpoints will remain lit when they are in the dark part of the bar graph, and they will be dark when they are in the lit part of the bar graph. The ESCAPE key is used to exit this utility.

The **BUTTONS** item is used to test the front panel buttons. When active the display will show the name of the last button pressed. This is useful if there is the possibility that one or more of the buttons have failed. Simultaneously press the ENTER key and the ESCAPE key to exit this utility.

If the machine has the analog output option installed there will be another utility available called **AN OUT**. This is used for calibration and testing of the analog output. There are five menu items in this utility.

When the display shows ZERO, pressing ENTER forces the analog output to 4 mA. When the display shows SPAN, pressing ENTER forces the analog output to 20 mA. These are intended for use in calibrating the analog output. These two functions are used while adjusting the analog output span and zero pots found on the Sensor board in the LevelCom 100. The 25%, 50%, and 75% items work the same way forcing the analog output to 8 mA, 12 mA, and 16 mA respectively. They are useful for verifying the linearity of the analog output, and are also useful for testing the field devices driven by the analog output.

Again it is the responsibility of the operator to use this utility in a safe manner. If the analog output is used as a control output the controlled process must be secured before using this utility.

If the LevelCom 100 is configured to communicate with LevelCom 101 digital repeaters there will be a menu item available called **DIGITAL COMMUNICATION**. Under this item are a number of utilities for troubleshooting the digital communication interface.

Finally the last item in this menu is the **FIELD CAL** procedure already described in the calibration section on page 55.

Analog Output Troubleshooting

The analog output is a 4-20 mA output. The output may be run as a self-powered output (in which case the LevelCom 100 provides power) or as an externally powered. When set up to be externally powered the analog output circuit is electrically isolated from the rest of the LevelCom 100. If the analog output does not work check the following:

Check the connections to the Analog Output terminals. Make sure the correct connector is wired, and verify the polarity of the wiring. It may be that something is wired backwards in the loop. Refer to the wiring diagrams in the installation section of the manual.

Check the jumpers on the sensor board and make sure that the analog output is configured as self powered or isolated. Refer to Figure 7 and Figure 6 for the proper jumper settings. If the jumpers are in the wrong position the output will not work.

If your machine has the LC100-A2 or -A3 sensor input circuit board, the analog output is contained in a small circuit board attached to the sensor input board. There is an LED on the analog output board next to the ZERO potentiometer that flashes to indicate that the board is functioning. Refer to Figure 13 for location of this LED. If this LED is not flashing the analog output module has probably failed, and should be replaced.

Digital Repeater Communication Troubleshooting

The Digital communication output is based on an RS-485 physical interface. It uses the connector for the Analog Output to connect its signal wiring. If you are experiencing trouble communicating with LevelCom 101 Repeaters using the digital communication option, check the following.

1. There is an LED on the LC101-DC1 Digital Communication Interface board, mounted on the sensor input board inside the LevelCom 100. If the interface board is functioning correctly this LED will flash. If this LED is not flashing the board may have a problem. A second

check for this is to enter the configuration menus and see if the DIGITAL COMMUNICATION option is available under the OUTPUTS menu. The communication interface is automatically detected when the LevelCom 100 is powered up. If the interface is not working you will find the ANALOG OUTPUT option under the OUTPUTS menu rather than the DIGITAL COMMUNICATION option. In this case the communication interface board will have to be replaced.

2. Check to see that the jumpers on the sensor board are set up correctly. See Figure 7 and Figure 6. The jumpers need to be set as shown for Externally Powered Loop.
3. Make sure that the polarity of the wires in the connector is correct. You could try swapping the polarity to see if things work.
4. If the jumpers are set correctly make sure all ID numbers are set up correctly on both the LevelCom 100 and the LevelCom 101 Repeaters. If these check out, and if they were just configured try cycling power to all machines. To check these configurations refer to page 46.

The **DIGITAL COMMUNICATION** tools under the CALIBRATE menu can be used to check the function of the digital communication module in the LevelCom 100. The items under this menu are listed here with their function.

COMM STATE: This item is of limited use for troubleshooting. It is used for development of the software on the communication module itself.

HOST TIMEOUT COUNT: This counts attempts to communicate with the installed module that failed for some reason. If this counter is counting up there may be a physical problem with the module. The module was successfully detected by the LevelCom 100 on startup but it is having trouble communicating.

MOD FAIL COUNT: If the LevelCom 100 tries to communicate with the installed Digital Communication module and the communication fails this counter is incremented. If this counter is counting up it means that there might be problems with the installation of the communication module. Check that the screws securing the communication module to the sensor circuit board are installed and tight.

MOD SER FAIL COUNT: This counter counts failures to communicate with LevelCom 101 repeater modules. If this counter is counting it suggests a wiring problem between the LevelCom 100 and the repeater. Alternately the repeater may not be configured with the proper address. At present there is a problem with the program on the digital communication module and this counter will increment during normal operation.

MOD SER NACK COUNT: This counter counts NO ACK messages sent back from the repeaters. If this counter is counting there is probably intermittent trouble with the wiring between the LevelCom 100 and the repeaters. Messages are getting through but some are garbled and not readable by the repeater. The repeater sends a NO ACK message to signal this condition.

REPEATER STATE: There are four items in this, selected by using the UP or DOWN buttons. Each possible repeater is shown,

here, listed as ID1 – ID4. The state of a repeater is one of three possibilities. If it is set up to communicate and communication is functioning it will show as ID1 GOOD. If it is set up but not communicating it will show as ID1 NO COMM. If it is disabled (network address set to 255) it will show as ID2 NOT USED. This item can help to identify problems if there are multiple repeaters and some are working and some are not. This can point to configuration issues in the repeaters, network addresses not set up correctly, or trouble with the wiring between the repeaters and the LevelCom 100.

Modbus Troubleshooting

If the LevelCom 100 is not communicating on the Modbus interface first check that it is configured to use the Modbus protocol.

After the wiring is verified the next thing to check is the wiring. Verify that the communication interface is wired correctly, use Appendix A as a guide for wiring.

Verify that the Modbus Address is set correctly. See Modbus Communication in the advanced Setup section of this manual.

Verify that the baud rate and parity settings are correct. There are some complications with the parity settings, especially in the case where no parity information is sent. In communications with desktop computers the most common parity setting is N-8-1, no parity, 8 bits per byte, 1 stop bit. In some PLCs though the only available no parity setting is equivalent to N-8-2, no parity, 8 bits per byte, 2 stop bits. When there is a mix up between these types the machines will communicate sometimes, but not reliably, or only in one direction. The second stop bit can sometimes be detected as the start bit of the next byte if an

N-8-2 setup is communicating with a N-8-1 setup. This results in framing errors at the receiving end and failed communication. See the Serial Communication section on page 20.

Under the COMM SETUP menu in the UTILITIES menu there is an item called DIAGS. The standard Modbus error counters are accessible here and they can be useful to help troubleshoot Modbus communication problems. The items in this menu are as follows

EVENT COUNT: Counts messages sent to the LevelCom 100 that were successfully received and processed.

EXCEPTION COUNT: Counts messages sent to the LevelCom 100 that were successfully received that generated exceptions. These are messages that cannot be serviced because of parameters out of bounds, or there is a command that is not supported by the LevelCom 100.

MESSAGE COUNT: Counts all messages on the Modbus network, including messages not directed at the LevelCom 100.

CRC ERROR COUNT: Counts messages sent to the LevelCom 100 who's calculated CRC did not agree with the CRC in the message. This suggests noise in the network is garbling message traffic. If this counter is counting continuously check the network wiring for faults or bad connections.

CLEAR COUNTERS: This utility is used to clear the Modbus counters. This is useful when you start troubleshooting to see what the counters are doing now. If the network has been operating continuously for a long time there may be non-zero count values on the error counters even if

the events counted are relatively rare. It is important to know if there is a real problem or not. Clear the counters at the beginning of a troubleshooting session to avoid confusion. The values of the error counters are also remotely readable through the Modbus interface. See the Modbus register map section on page 70

The HARDWARE Menu

There is a special menu on the LevelCom 100 that is used to configure or read installed hardware options. Most of these options are indications only and are not changeable by the operator. They are automatically detected by the LevelCom 100 when it first starts operation, and the devices detected are shown here for troubleshooting. There are some options that can be changed here though; Automatic Specific Gravity, Differential Pressure, Passive Gauge, and Sample Timing.

It is very important to understand the function of the configurable parameters before changing them. If these are set up incorrectly the machine will not function correctly. Operators should contact TMS before changing any of these settings. It is important to understand what each option does. The following section describes all options under the HARDWARE.

Accessing the Hardware menu

First you must set up temporary a password in the LevelCom 100 if there isn't already a password programmed (A for example). If there is already a password programmed into the machine you don't have to change it. You need a password in the machine so that you will be asked to enter a password before entering the operator interface.

Now enter the configuration menus, when the machine asks for you to enter the password, use the special password SETXYZ.

After entering the password the machine will display SYSTEM. Press UP and the machine will display UTILITIES.

Press ENTER, the machine will display COMM SETUP. Press UP and the machine will display HARDWARE. This is the special hardware configuration menu. You must enter the configuration interface using the password SETXYZ to have access to this menu. Normally it isn't available in the UTILITIES menu.

Press ENTER, the machine will display 15 PSI.

The menu begins with a list of possible pressure sensor types and other optional hardware installed. You will see an asterisk * in the rightmost character in the interface identifying the options installed. If an option can be activated by the operator, the MENU key is pressed to activate or deactivate that item. In this case the asterisk indicates that the item is active.

The list with descriptions of each item is as follows. You will use the DOWN arrow button to scroll through this list:

15 PSI: A 15 psi sensor is installed. Not modifiable.

30 PSI: A 30 psi sensor is installed. Not modifiable.

100 PSI: A 100 psi sensor installed. Not modifiable.

100 PSI DEEP: A 100 psi pressure sensor with optional double range span setup.

This option is not produced any more but will be encountered on older installations that are upgrading firmware. This option will be needed on any firmware upgrade if there is a D after the firmware revision number and the installed sensor is a 100 PSI sensor, for example V2.83D. To activate this item press the MENU key and an asterisk will appear in the right most character in the display. If the item is already activated and the operator wishes to deactivate the item, press the MENU key and the asterisk will disappear. Press Enter to save this selection.

100 PSI 16 BIT: A 100 psi sensor is installed with the optional 16 bit A/D converter. Not modifiable.

RELAYS: The optional relay module is installed. Not modifiable.

A OUT: The optional analog output module is installed. Not modifiable. Note this item will show an asterisk if the optional Digital Communication Interface Controller is installed. This is normal.

A IN: The LevelCom 100 is built to take input from an external 4-20 mA transmitter rather than the typical internal sensor. Not modifiable. This option is obsolete and should not be encountered.

HORN: The optional piezoelectric horn is installed in the machine. Not modifiable.

S G: The machine is built to read specific gravity. This option uses another sense line and must have another output valve built into the pneumatic manifold to function. This item is configurable through this menu. To activate this item press the MENU key and an asterisk will appear in the right most character in the display. If the item is already activated and the op-

erator wishes to deactivate the item, press the MENU key and the asterisk will disappear. Press Enter to save this selection. It is important to verify that the specific gravity sense line and valve are present. Activating this item on a standard LevelCom 100 can lead to problems in normal operation and confusing error messages.

DIFF P: The machine is built to read the pressure in the tank above the liquid. This option uses another sense line and must have another output valve built into the pneumatic manifold to function. This item is configurable through this menu. To activate this item press the MENU key and an asterisk will appear in the right most character in the display. If the item is already activated and the operator wishes to deactivate the item, press the MENU key and the asterisk will disappear. Press Enter to save this selection. It is important to verify that the differential pressure sense line and valve are present. Activating this item on a standard LevelCom 100 can lead to problems in normal operation and confusing error messages.

PASSIVE GAUGE: The machine is configured to read a sense line only. It will not apply air to the sense line. In rare instances two machines are used to read a single sense line. One machine controls the air to the sense line, and operates normally. The other machine is configured as a passive gauge and will not apply any air to the sense line. This configuration prevents the two machines from interfering with each other. To activate this item press the MENU key and an asterisk will appear in the right most character in the display. If the item is already activated and the operator wishes to deactivate the item, press the MENU key and the asterisk will disappear. Press Enter to save this selection.

SAMPLE TIMING: This parameter is used to set the time the machine waits after putting a charge of air on the line to take a sample of the line pressure. When using longer sense lines this waiting time must be increased.

Press ENTER to view the current value. When you are viewing the parameter you can use the UP and DOWN keys to change the value. When the desired value is shown on the display press ENTER to save the new value.

This timing parameter does not have units, however a larger value of the timing parameter results in longer delay times in sampling. Lengths of up to 600 feet of poly tubing have been tested and below are suggested timing parameter values. You should only set the timing parameter large enough to get correct operation. You don't want to unnecessarily slow the machine's operation.

Timing parameter values for different lengths of ¼ inch poly tubing

100 feet	1
200 feet	3
300 feet	7
400 feet	10
500 feet	14
600 feet	18

You can tell if the timing parameter is too small by watching the machine sample the sense line. The machine will put two or three charges of air on the sense line in a normal sample operation. If the readings are not consistent between these charges of air the machine will put a larger charge

of air on the line which you can hear. After all charges of air the display is updated. You can see the measured depth rise when the machine samples, and after the sample operation is complete the depth will settle back to down to a lower value.

When the larger blast of air is triggered on every sample operation, and especially if the measured depth changes much during the sample operation, the machine will eventually indicate a leak.

Once the timing parameter is set up correctly the leak detection logic functions correctly, and if the machine still indicates a leak condition there is probably a real leak in the sense line.

The above timing parameter values were derived from tests at TMS. Different sense line materials have different effects on timing. For instance a LevelCom 100 will function correctly with the default timing parameter value of 1 on over 300 feet of ¼ inch copper tubing. Poly tubing has a greater resistance to gas flow than similar sized copper tubing.

If you need to set the parameter very differently from the values shown in the table above and you are using ¼ inch tubing, there is probably something wrong with the installation. The sense line may be kinked somewhere causing a near complete blockage. Check the installation first before adjusting the value of this parameter from it's normal value of 1. Adjusting this parameter is the last resort and should not be done without eliminating all other sense line problem sources first.

Appendix A

Serial Network Wiring Diagrams

The diagrams in this section show the wiring for various RS485 installations. Both 5 wire and three wire networks are supported. See the documentation on the master device for the connections. There is not a standard pinout for 9 pin D sub-miniature connectors so none is shown here. If you are using a plug in expansion card in a PC the documentation for the card will show the correct pinout for the connectors.

RS-485 connections may be wired to single nodes or multiple nodes. These drawings show multiple node connections

For low speed communications terminating resistors may not be needed, check the documentation with the computer interface for the value of these resistors if needed.

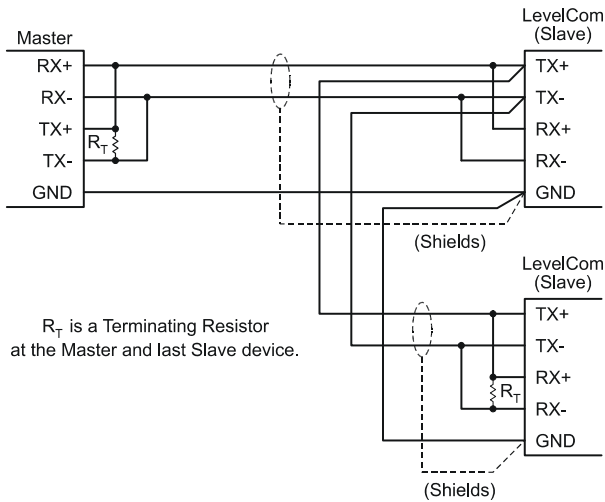

Figure 15 3 Wire RS-422/485 Wiring

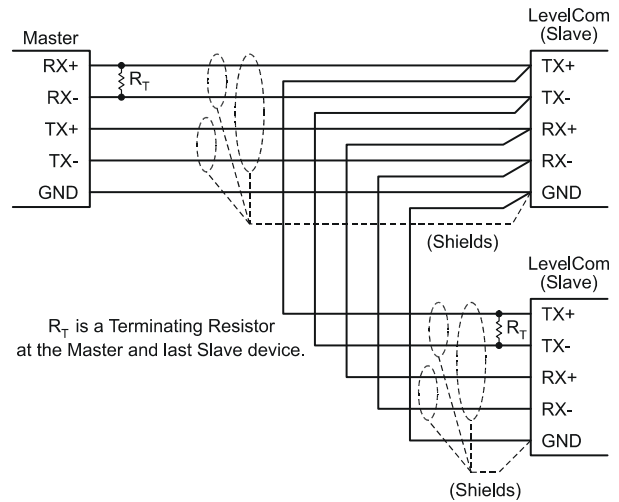

Figure 14 5 Wire RS-422/485 Wiring

Appendix B

Modbus Register Values

Following is a map of the input/output registers and coils available in the LevelCom 100 for Modbus communications.

Read functions:

30001	Level	Level in 0.1 inches
30002	Specific Gravity	Specific Gravity x 1000
30003	Volume (1)	Volume is combined in registers 30003 & 30004 to form a long integer. See note 1 below.
30004	Volume (2)	
30006	Status Bits	Status codes as bits. See note 2 below.
30007	Max Depth	Programmed Max Depth in 0.1 inches
30008	HiHi Alarm	HiHi alarm set point in 0.1 inches
30009	Hi	Hi alarm set point in 0.1 inches
30010	Lo	Lo alarm set point in 0.1 inches
30011	LoLo	LoLo alarm set point in 0.1 inches
The above registers are mirrored in the following holding registers:		
40001	Level	Level in 0.1 inches
40002	Specific Gravity	Specific Gravity x 1000
40003	Volume (1)	Volume is combined in registers 30003 & 30004 to form a long integer. See note 1 below.
40004	Volume (2)	
40006	Status Bits	Status codes as bits. See note 2 below.
40007	Max Depth	Programmed Max Depth in 0.1 inches
40008	HiHi Alarm	HiHi alarm set point in 0.1 inches
40009	Hi	Hi alarm set point in 0.1 inches
40010	Lo	Lo alarm set point in 0.1 inches
40011	LoLo	LoLo alarm set point in 0.1 inches

The following coil bits signal various conditions in the LevelCom as noted:

10001	HiHi Alarm	1 = HiHi alarm activated
10002	Hi Alarm	1 = Hi alarm activated
10003	Lo Alarm	1 = Lo alarm activated
10004	LoLo	1 = LoLo alarm activated
10005	Big Number	See note 1 below
10006	Loop failure	1 = 4-20 mA loop failure
10007	SG line over pressure	1 = SG sense line is over pressurized (plugged)
10008	DP line over pressure	1 = DP sense line is over pressurized (plugged)
10009	EPROM failure	1 = EPROM failure
10010	Sense line leak	1 = Main sense line is leaking
10011	Sense line over Pressure	1 = Main sense line is over pressurized (plugged)
10012	Check Air	1 = Low supply air pressure

Write functions:

Writing values to the following registers allows the specific gravity and alarm set points to be modified remotely. Note that writing to these registers will update the configuration of the LevelCom 100.

The normal value of these registers is 0. A non-zero value in one of these registers causes the LevelCom to update the internal configuration, and after this is done, the LevelCom writes a 0 value back to the register. This return to 0 can be used as a signal that the operation is complete.

40012	Specific Gravity	Specific Gravity x 1000
40013	HiHi Alarm	HiHi alarm set point in 0.1 inches
40014	Hi Alarm	Hi alarm set point in 0.1 inches
40015	Lo Alarm	Lo alarm set point in 0.1 inches
40016	LoLo Alarm	LoLo alarm set point in 0.1 inches

Setting the following coil bits triggers the actions as noted. When the action is initiated by the LevelCom 100 the coil is cleared and reset to "0".

00001	Purge Now	Triggers the purge cycle
00002	Sample Now	Forces a new level sample
00003	Acknowledge	Allows remote acknowledge for alarm and fault conditions
00004	Restart	Restarts the LevelCom

Notes:

1. Base units and Big Number

Level and volume are stored in the LevelCom 100 in specific base units. These values are scaled for display on the LevelCom 100 based on the desired output units. The Modbus data is given only in the base units and must be converted by the user application.

Level is reported by the LevelCom 100 in 0.1 inches. The conversion factors for the other units available in the LevelCom 100 are as follows:

Feet = 0.1 inches / 120
Centimeters = 0.1 inches x .254
Meters = 0.1 inches x .00254

Volume is reported by the LevelCom 100 in two possible base units. You must check the Big Number flag in output register 10005. If this coil is set then the base output units are full liters, if the flag is not set the output units are in 0.1 liters. This flag will only be set if an extraordinarily large volume or weight value is input into

the Tank Table during the programming of the LevelCom 100. The default condition is Big Number = 0, volume reported in 0.1 liters.

Assuming Big Number = 0 the conversion factors for the other units available in the LevelCom 100 are as follows:

Gallons = 0.1 liters / 37.85306
K Gallons = 0.1 liters / 37853.06
Liters = 0.1 liters / 10
K Liters = 0.1 liters / 10000
Cubic Feet = 0.1 liters / 283.1605
Barrels = 0.1 liters / 1589.829

These conversion factors must be divided by 10 if the Big Number flag is set and the base units are liters.

Volume is a long (32 bit) integer. Since the registers are only 16 bits long the volume is stored in two registers. To get the actual volume registers 30003 and 30004 must be combined in the following way:

Volume = ((register 30003) * 65536) + (register 30004)

2. Registers 30006 & 40006 - Status Bits

These registers can be used in place of the 1XXXX coil registers. The bit functions are defined below.

EPROM Failure	0x0001
Check Air	0x0002
Sense line over pressure	0x0004
Loop failure	0x0008
Sense line leak	0x0010
SG sense line over pressure	0x0020
DP sense line over pressure	0x0040
SG sense line leak	0x0080
Big Number flag	0x0100
HiHi Alarm	0x8000
Hi Alarm	0x4000
Lo Alarm	0x2000
LoLo	0x1000

Configuration Interface Map

The following pages are a map of the configuration interface. Use these maps to find your way around the interface.

First a simple map is given as a general guide to the interface. This can be used as a quick reminder for operators who already have experience configuring LevelCom 100s. Many details are left out in this diagram to make it fit on a single page.

Following the simple map is a detailed map of the complete configuration interface. This map is spread out over six pages so be careful in using it. Most of the main menu items are documented on a single page.

On the first page of the detailed map is a key to the symbols used in the map. If you don't understand the symbols you should re-read the sections of this manual and refer to this map as you read to get familiar with the layout of the map. Once you are familiar with the configuration interface you should be able to get around quickly just using the map.

Generally to navigate the configuration interface you use the UP and DOWN arrow buttons to move through the items in a single menu, you use the ENTER button to move one level into the interface, and you use the ESCAPE button to move one level back. In the diagram this corresponds to moving to the right using the ENTER button, and moving to the left using the ESCAPE button.

Simplified Configuration Interface Map

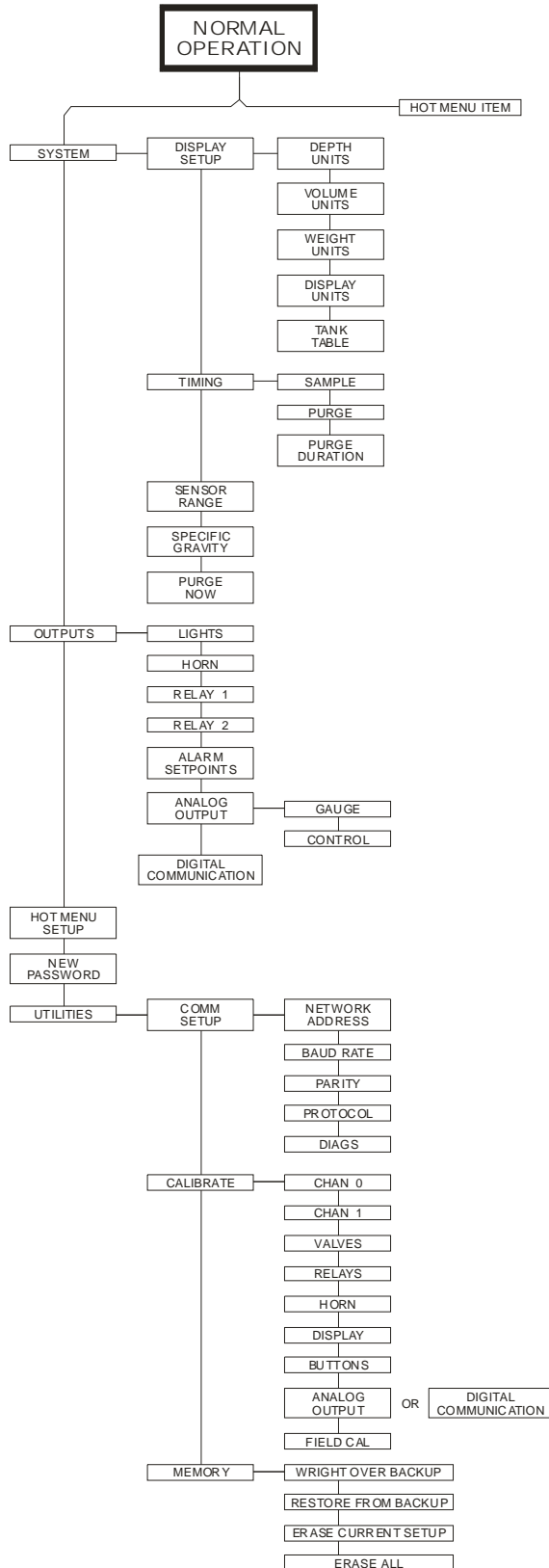

LEVELCom 100 LIQUID LEVEL COMPUTER





Version 2.92 DATE 6/2008

Technical Marine Service, Inc.
Portland, Oregon

Detailed Configuration Interface Map

LEVEL.Com 100 LIQUID LEVEL COMPUTER
 Program Flow Chart
 Version 2.92 DATE 6/2008
 Technical Marine Service, Inc.
 Portland, Oregon

KEY

MODE BUTTON	USED TO ENTER PROGRAM MODE AND SELECT OR DESELECT PARAMETERS
ESCAPE BUTTON	EXIT LEFT TO THE PREVIOUS BOX
ENTER BUTTON	ADVANCE RIGHT TO THE NEXT BOX WHILE SAVING CHANGES TO THE CURRENT CONFIGURATION
UP BUTTON	MOVES UP THROUGH A MENU
DOWN BUTTON	MOVES DOWN THROUGH A MENU
	MESSAGE DISPLAYED AT EACH STATION
	WHERE VARIABLES ARE ENTERED WITH UP AND DOWN BUTTONS
	MENU BUTTON SETS FLAG TO ACTIVATE OPTION
	ITEMS THAT CAN BE ADDED TO THE "HOT MENU"

